



2025

Modified Outboard Technical Manual

Version: April 2, 2025

Rule changes for 2025:

AMH/ AMR/ BMH/ BMR Hot Rod – The use of the 15 / 20 Sidewinder gear box is legal on the A mod and B Mod Hot Rod engines. Class vote

AMH / AMR – The Mercury KG4H / Mark 15 series engine and the OMC / Mercury 22 CI (stock configuration) engines are no longer legal engines in the A MOD class. Voted out by class vote 2025.

Formula E / Mod 2-person Runabout – The Tohatsu engine (only) is allowed to over bore to .090 to accommodate only available oversize pistons. Class vote.

All Modified classes – Clarification: Use of any bearing, seal or gasket is allowed.

Rule changes for 2024:

MOD 125R – The Formula A OMC engine (formerly 200cc) is allowed to run in Mod 125 Runabout. To be raced under Formula A Runabout OMC rules and weight.

Formula E / Mod 2-person Runabout – Mercury MK 78 (66 CI) engine is legal in Formula E and Mod two-person Runabout under D Modified engine specifications.

Formula 400 / BMH – The OMC 25 Modified engine running in Formula 400 and BMH has updated manufacturer flywheel dimensions. The M dimension is 5.950, N dimension is 1.600

Mod 125 – Engine specifications updated to meet actual measurements from field inspections.

Modified Tech Manual - New format developed to clarify rules by classes. Each engine will have its own set of rules.

B Mod and C Mod Yamato – Roskowski aftermarket ignition system approved for use on B and C Yamato Hydro and Runabout

Rule changes for 2023:

125MH / 125MR – Established maximum gear ratio and on-board starter switch detail.

200MH – Allows the AXS engine (in stock specifications) in 200MH only.

AX weight in 200MH to be 345 lbs.

AX age in 200M to be 14 years of age.

AX engine is not legal in 200MR by class vote.

350MR – 25XS weight increase to 415lbs.

400MH – Removal of OMC port specification A, A1, C, C1.

2025 Modified Outboard Tech Manual

Table of Contents

<u>Hulls:</u>	<u>Page</u>
General boat hull rules	3
Runabouts: Formula A, A, B, C	3
Runabouts: D, Formula E, Two-person Runabout	4
Hydroplanes: Formula A, A, B, Formula 400, C, D, Formula E	5
Weights / Scales	6
<u>Levels of Inspection:</u>	
Level 1 – All races	7
Level 2 – Divisionals, Championships	7
Level 3 – Summer Nationals, Record Runs	7
Combustion Chamber Volume measuring liquid	7
<u>Fuel</u>	
General	7
Test Procedure - Digitron Models DT-15 / DT-47 / DFT-64	8
Test Procedure - Specific Gravity	9
Test Procedure – Water Solubility	9
Test Procedure – Germaine Reagent	10
Test Procedure – Ceric Nitrate Fuel	11
<u>Class Rules</u>	
Mod 125 Class (Formerly 125cc)	
PRD Fireball (Hydro and Runabout)	
Formula A OMC engine (Runabout only)	12-19
Formula A (Formerly 200cc)	
Evinrude EKT, Johnson JKT	
Mercury AX (Hydro only)	20 - 25
Class A (Formerly 250cc)	
Hot Rod	26 - 32
Mercury 20H (Stock Configuration)	33 - 35
Sidewinder 15S and 15H	36 - 39
Mercury KG4H / Mark 15 engine removed from A Mod class	
22 CI OMC & Mercury (Stock) removed from A Mod Class	
Class B (Formerly 350cc)	
Yamato Y-80	40 - 45
OMC 22.1 CI. / Mercury.25SS, 22.0 CI	46 - 52
Hot Rod /Mercury 20.0 CI	53 - 60
Mercury / Mariner 25XS (BMR only)	61 - 63
Formula 400 (Formerly 400cc) Classes	
OMC 22 / Mercury 22 CI /	
Hot Rod / Merc 20	64 - 69
Class C (Formerly 500cc)	
Yamato 102,302,321, 331	70 - 75
Mercury 30H, Wizard 30	76 - 81
Class D (Formerly 750cc)	
Mercury 44 CI / Mercury 40 CI	82 - 87
Formula E /Mod Two Person Runabout (Formerly 850cc)	
Powerheads / Modification of engines / Specification sheets	88 - 94

HULLS

GENERAL HULL RULES

- a. *Planning surfaces, fins, motor tilt devices, and devices which can raise and lower engine height on the transom, any or all of which are moveable or controllable while under way are not permitted. For such devices to be permitted, it must be constructed in such a manner as to require the driver to shut off the engine and stop the boat before adjustment is possible.*
- b. *Overall weight requirements:*
 1. *A boat stepping up into a larger class shall be required to have only the overall weight of its own class.*
 2. *As a safety item to encourage the use of "cut suits" (aka Kevlar) the overall racing weights for boats include cut suits and are as follows:*
- c. *Scales at races cannot be protested but must be available for use **one (1) hour before the start of the first heat of each day's racing.***
- d. *Any device may be used as a brake if its sole purpose is to reduce the speed of the boat.*
 1. *If a brake is used it must be mounted within 8" of the centerline (or keel) at the transom and be mounted on the starboard side. Brakes must be in a "neutral" mode and have no effect on turning. The aspect ratio of any brake (side view/front view ratio) may not be more than 1.5:1*
- e. *The Formula E Modified class can use a transom rudder system for steering purposes which is not retractable and cannot be elevated while underway.*
- f. *All fuel tanks must have an opening sufficient for a Digitron fuel meter probe to pass unobstructed into the fuel tank. **1.050** is the diameter of the probe.*
- g. *All weights must be securely fastened to the hull.*

RUNABOUT HULLS – Formula A, A, B, and C Modified Runabout

- a. *Boats in these classes are defined as displacement type hull, having no step, no breaks in the longitudinal or transverse continuity of the immersed surface other than the keel, rubbing strips or lapstrake of no greater than 3/4" and parallel to the center line of the boat.*
- b. *Boats in these classes will not be permitted to depend on external air pressure or designs which create a "tunnel" effect to aid planning.*
- c. *Turning fins may be used.*
- d. *Runabouts will not be required to have a forward cockpit and are not required to conform to any maximum or minimum dimension restrictions.*
- e. *Transverse concavity of runabout running surface of 1/32" per foot (12") as measured from high point to high point across running surface width is permitted.*
- f. *Any runabout hull permitted for racing in the Stock Outboard Division of APBA shall be permitted in the Modified Division.*
- g. *On "Deep V" runabouts having a positive dead rise angle of more than 10 degrees rule "e" will not apply. However, the following restrictions will apply to those hulls.*
 1. *The maximum width of running pad (keel) is **10"***
 2. *Surfaces with negative dead rise angles are not permitted.*
 3. *Stability strakes with a maximum depth of 1" are permitted, but placement of said strakes specifically to trap air are prohibited.*

- h. Hulls shall not have a sponson/pod protruding from the side of the boat which interrupts the line of the side, bottom, or non-trip of the boat
- i. Lifting rails such as those used on DeSilva "Pro" racing runabouts are permitted.
- j. Some 1985-1987 DeSilva model KR runabouts have a concave tunnel in the right chine (see diagram) and are permitted in the Modified category. However, hulls having a tunnel chine in both sides are not permitted.

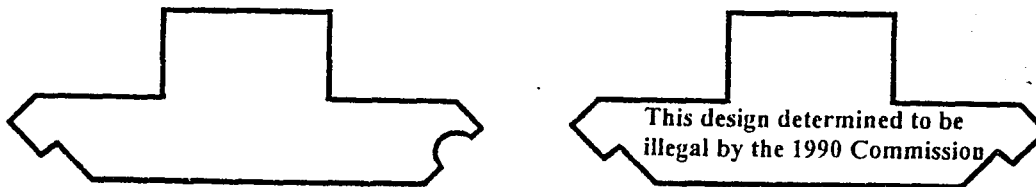

The drawings above are to be enforced for the Formula A Modified, A Modified, B Modified, and C Modified runabout classes only.

RUNABOUT HULLS – D, Formula E and Two-person Modified Runabout

- K. The D, Formula E and Two-person Modified runabout racing hull must conform to the following:
 - a. The bottom shall have no steps or breaks in the longitudinal continuity.
 - b. The bottom must not have any of the following:
 - i. Tunnel
 - ii. A concavity greater than one-sixteenth (1/16) of an inch within the planning surface
 - iii. Any design that uses a tunnel effect
 - c. The side of the boat must form a continuous contour from a single stem to transom and must have no concavity greater than one-quarter (1/4) inch. The side of the boat referred to in Section "c" shall be interpreted as the outside chine.
 - d. Trim tabs which are adjustable by the driver while underway shall not be allowed.
 - e. Rub rails will be allowed provided:
 - i. They are attached to the extreme outside of the boat
 - ii. They do not exceed 1.5" in depth and width
- l. Runabout length shall be measured from top of transom along centerline to tip of bow excluding any hardware or other devices added to the boat to extend its overall length. **Length in D, Formula E and Two-person Modified shall be 12' minimum.**
- m. Hulls shall not have a sponson/pod protruding from the side of the boat which interrupts the line of the side, bottom, or non-trip of the boat. Turning fins and turning fin brackets on D Mod and FE / Two Person runabouts may not protrude more than one (1) inch beyond the chine of the hull where it is mounted.

HYDROPLANE HULLS

- a. Any boat having multiple planing surfaces, and which cannot qualify as a runabout will be considered a hydroplane. This shall specifically include "tunnel boats" as permitted hydroplanes in this Division.
- b. Turning fins are permitted.
- c. There shall be no specifications or restrictions placed on hydroplanes in this Division except:
 1. **Effective November 1, 2007, all MO hydroplane hulls shall have a construction date permanently affixed to the inside of the transom in a location easily visible to the Inspector. If the actual construction date of a hull is unknown, a one-time declaration of a construction date (month and year) may be permanently affixed by the owner or driver to the inside of the transom.**
 2. All MO hydroplane hulls built after October 31, 2007, will have the foremost points of sponson pickle forks that meet the following requirements for shape. The foremost points of the pickle forks shall have a minimum radius of 1" in one view. This minimum radius shall extend at least 45 degrees to both sides of the foremost point. At 90 degrees to this radius conforming view, the foremost points on the pickle fork will have a minimum thickness of $\frac{3}{4}$ ". This minimum thickness shall extend at least 45 degrees to both sides of the foremost point.
 3. All MO hydroplane hulls built after October 31, 2007, where the cockpit nose extends forward of the body of the hull, shall have a cockpit nose that conforms to the same requirements for shape as the pickle fork foremost points described in paragraph 2 above.
 4. Half oval aluminum rub molding may be used around the foremost points of pickle forks and cockpit noses provided the molding is at least $\frac{1}{2}$ " in width.
 5. This rule does not apply to hulls that conform to runabout specifications, conventional round-nose hydroplane hulls without pickle forks or sponson noses that extend forward of the body of the hull, or tunnel hulls that conform to OPC specifications for collapsible sponson noses.
 6. All laydown boats shall have left, and right mirrors positioned in such a way that they allow rear vision from the driving position. Each mirror must be a minimum of six (6) square inches of reflective surface. Mirrors are not required during kilo trials. In the event a mirror is displaced or broken during racing, replacement is not required until the next attended event.

2024 APBA MODIFIED OUTBOARD - MINIMUM BOAT WEIGHT

<i>Class</i>	<i>Engine</i>	<i>Minimum Weight</i>
Mod 125H	PRD - Fireball (2018 MORC)	350 lbs.
Mod 125R	PRD - Fireball (2018 MORC)	350 lbs.
Mod 125R	OMC - Model KT (1.375" Bottom to prop center line)	350 lbs.
Formula AMH	OMC - Model KT (1.375" Bottom to prop center line, 1/2" tuck max)	345 lbs.
Formula AMH	AX Mercury – Stoc specs. (1.375 bottom to prop center line, 1/2' tuck Max. Min age is 14 years old)	345 lbs.
Formula AMR	OMC - Model KT (1.375" Bottom to prop center line)	350 lbs.
AMH	A Hot Rod, Sidewinder 15S/15H, Merc 20 H (1987 engine spec)	365 lbs.
AMR	A Hot Rod, A Mercury, Sidewinder 15S/15H, Merc 20 H (1987 engine spec)	360 lbs.
BMH	Yamato Y-80	420 lbs.
	Merc 25SS/22.0 cu in., OMC 22.1 cu in.	395 lbs.
	Hot Rod 20	370 lbs.
	Merc - 20 Cu In	350 lbs.
BMR	Yamato Y-80	415 lbs.
	Merc 25SS/22.0 cu in., OMC 22.1 cu in.	390 lbs.
	Hot Rod 20	390 lbs.
	Merc 25XS ("HHP" restrictor, 1.00" Bottom to prop center line)	415 lbs.
	Merc - 20 Cu In	370 lbs.
Formula 400MH	Merc 25SS/22.0 cu in., OMC 22.1 cu in, Hot Rod 20	370 lbs.
	Merc - 20 Cu In	350 lbs.
CMH	Yamato 100/300 series, Mercury 30	440 lbs.
CMR	Yamato 100/300 series, Mercury 30	480 lbs.
DMH	Mercury 44 Cu In	470 lbs.
	Mercury 40 Cu In	450 lbs.
DMR	Mercury 44 & 40 Cu In	475 lbs.
Formula EMH	OMC, Tohatsu, Merc 44/650/650SX, 6 Cylinder MK 75, 6 Cylinder MK 78, Yamaha	No Weights
Formula EMR Two-Person R	OMC, Tohatsu, Merc 44/650/650SX, 6 Cylinder Mk75 6 Cylinder MK 78, Yamaha	No Weights

Min. 12'-0" length

LEVELS OF INSPECTION

Level 1 – At all races, Inspection shall consist of:

- **Height**
- **Weight**
- **Tuck**
- **Fuel checked with the Digatron meter.**

Level 2 – At Divisionals, Championships

(Winter Nationals, North American Championships):

- **All items in a Level 1 Inspection plus:**
- **Gearcase Letters R & S and check the ratio.**
- **Check bore and stroke.**
- **Measure the carburetor throat and venturi.**
- **The combustion chamber volume must be measured.**

Level 3 – Summer Nationals and Record Races

- **All items in a Level 1 and Level 2 Inspection plus**
- **Internal Inspection to verify that internal dimensions comply with current Modified rules. (2020 Commission)**

COMBUSTION CHAMBER VOLUME FLUID MEASURING LIQUID

**A mixture of 50% Mineral Spirits and 50% Marvel Mystery Oil
or
50% Kerosene and 50% Marvel Mystery Oil
shall be used to measure the combustion chamber volume.**

FUEL

1. **Permissible fuels for use in the Modified Outboard classes shall consist of gasoline and oil only. Gasoline may be aviation, automobile, of either lead or unleaded varieties and includes automobile racing gasoline so long as it does not contain alcohol, nitrates, oxygen bearing compounds or other such power boosting additives. Gasohol is not a permitted fuel. Oils may be petroleum or synthetic and cannot contain power boosting additives. All oil must be made for 2-cycle engines. Any driver using fuel which does not meet this rule will be disqualified. Additional fuel disqualification on the same day will result in the driver being automatically suspended for the remainder of the day.**
2. **At each Regatta, the Inspector may purchase a sample of local gasoline, mix it with TC III oil at a ratio of 8:1 and test it according to the Tech Manual. If the test fuel exceeds the 0 Digitron DT-15, DT-47 or FT-64 threshold, the higher reading will become the maximum limit of the day. The source and grade of the gasoline must be announced when Registration opens. At that time, testing equipment must be available to all competitors. The Fuel of the Day is not applicable at straightaway or Record races, Championships, or National events (Nationals, Winter Nationals, Divisionals, Regionals).**

FUEL TESTING PROCEDURES

Fuel testing procedures used may be one or all of the following methods and are at the discretion of the Inspector. The tests are as follows:

- a. *Digatron DT-15, Digatron DT-47, or Digatron FT-64 Meter*
- b. *Specific Gravity*
- c. *Water Solubility*
- d. *Germaine Reagent Fuel Test*
- e. *Ceric Nitrate Fuel Test*

DIGATRON DT-15/47-FT / FT-64 FUEL METER - TESTING INSTRUCTIONS

The purpose of this test is to measure certain electrical properties of the fuel sample and determine if they are within the permissible limits.

The test procedures described here are in accordance with the instructions supplied by the DT-15 Meter manufacturer.

Before performing your fuel test, ensure that the fuel meter is in good working order:

- a. *Sensor Condition – Visually check the sensor and its connecting wire to assure that it has not been physically damaged.*
- b. *Battery Condition – When the meter is on, the words “LO BAT” will appear in the upper left-hand corner of the display if the battery needs to be replaced. Do not use the meter if the “LO BAT” message is displayed, as its readings will not be accurate.*

The recommended fuel test procedure is as indicated below:

1. *Calibrate the DT-15 and 47-Ft meters as follows:*
 - a. *Turn the meter on and allow it to warm up for at least 15 minutes before doing any testing. This will allow the internal components to stabilize at their normal operating temperature.*
 - b. *Attach the sensor’s connecting wire to the meter. Hold the sensor’s connecting wire and lower the sensor into the calibration liquid (Cyclohexane – C₆H₁₂) in such a way that the sensor is completely submerged. Take care to ensure that the sensor is not in contact with the fuel container. Gently wiggle the sensor wire to displace any air bubbles which may be trapped between the sensor plates. Using the knob on the front of the meter, adjust the meter until the display reads “-75”.*
2. *Calibrate the FT-64 meter as follows:*
 - a. *Press Exit /Power button.*
 - b. *Press Set button and hold 2 seconds. SEL/SEL will start blinking.*
 - c. *Press both Light and Set buttons at the same time to enter the calibration mode.*
 - d. *Place probe in appropriate amount of cyclohexane in a plastic or glass container.*
 - e. *Press the Up or Down arrows to adjust to -75.0.*
 - f. *Press the Exit/Power button to exit calibration.*
3. *Remove the sensor from the calibration liquid and dry any excess liquid from between the sensor plates. Lower the sensor into the fuel sample just like you did while calibrating the meter. Observe the reading on the meter’s display. If the reading is zero or a negative number, the tested fuel is permitted. If the reading is greater than zero (a positive number) the tested fuel is not permitted.*

The electrical characteristics of gasoline change somewhat with temperature. As such, it is important that the temperature of the fuel sample and the calibration liquid be within about 15° of each other.

When a fuel sample is found to be in violation of these rules per the above procedure, it is recommended the following steps be performed:

- a. *Clean the sensor with some spray-on brake cleaner and allow it air dry for at least 30 seconds.*
- b. *Recheck the calibration setting (-75) of the meter in the Cyclohexane and adjust the meter if necessary.*
- c. *Allow the fuel sample to stabilize to the same temperature as the Cyclohexane, then repeat the test as described in #3 above.*

During the course of the day, it is recommended that the calibration setting in the Cyclohexane be occasionally checked. It is interesting to note that calibration reading of “-75” in the Cyclohexane has a corresponding reading when the sensor is in the air. Although this corresponding air reading varies between individual meters, it tends to be quite consistent for each meter. As such, the specific corresponding air reading, for the meter being used, can be a useful reference during the time between occasional Cyclohexane calibration checks.

SPECIFIC GRAVITY TESTING INSTRUCTIONS

The purpose of this test is to measure the relative density of the fuel sample and determine if it is within the permissible limits.

Two pieces of equipment are required to perform this test:

1. Specific gravity hydrometers which cover the range of 0.750 – 0.800 (at 60° F).
2. A clear glass container which is at least as tall as the hydrometer. A “graduated cylinder” works well for this purpose.

The recommended fuel testing procedure is as indicated below:

- a. Assure that the glass container and hydrometer are clean.
- b. Place the glass container on an essentially level surface and fill it with the fuel which is to be tested. The depth of the fuel should be equal to, or greater than, the length of the hydrometer.
- c. Carefully insert the hydrometer into the fuel sample with the weighted end facing down. Take care to minimize the contact between the hydrometer and the container.
- d. When the hydrometer has reached a stable free float in the fuel sample, read the specific gravity from the scale within the hydrometer. This is done by visually sighting along the upper surface of the fuel and reading when the scale crosses the fuel’s surface. Record this reading.
- e. Measure the temperature on the fuel.
- f. The specific gravity characteristics of fuel (gasoline and oil) change somewhat with temperature. As such, the maximum permissible specific gravity reading will change as the fuel temperature changes. Following is a listing of the maximum permissible specific gravity readings and their corresponding fuel temperatures.

Fuel Temperature in Degrees Fahrenheit	Maximum Permissible Specific Gravity Reading	Fuel Temperature in Degrees Fahrenheit	Maximum Permissible Specific Gravity Reading
40	.785	80	.766
50	.780	90	.761
60	.775	100	.757
70	.771	110	.752

WATER SOLUBILITY TESTING INSTRUCTIONS

The purpose of this test is to determine if water soluble additives are present in a fuel sample.

The only piece of equipment necessary to perform this test is a graduated container. It is recommended that a good quality glass “graduated cylinder” be utilized, with the capacity of 100 ml and subdivisions of 1.0 ml or less.

The recommended testing procedure is as indicated below:

- a. Assure that the graduated container is clean.
- b. Place the graduated container on an essentially level surface.
- c. Pour approximately 35 ml of the fuel sample into the graduated container.

- d. Carefully measure and record the amount of fuel in the container (using the scale on the container)
- e. Slowly pour approximately 35 ml of water into the container.
- f. The liquid in the container will separate into two layers. The water will settle to the bottom of the container, carrying any water-soluble additive with it. Often a froth will form in the lower layer. As such, allow some time for the froth to clear.
- g. Carefully measure and record the total amount of liquid in the container.
- h. Subtract the amount of fuel in the cylinder (item d) from the total liquid (item g) to determine the exact amount of water which was added. Record this result.
- i. Carefully measure the amount of liquid in the lower layer of the container.
- j. If the amount of liquid in the lower layer (item i) is greater than the amount of water added (item h), the fuel contained water soluble additives and is not permitted.

THE GERMAINE REAGENT TEST

Equipment Required:

- a). Disposable test tubes
- b). Disposable eyedroppers or pipettes
- c). Test tube rack suitable to hold test tubes above.
- d). Protective latex or rubber gloves.
- e). Bottle of Germaine reagent

Optional:

- a). A bottle of 1,4 Dioxane
- b). A bottle of known legal fuel

Specified Procedure

1. Using a new, clean pipette or eye dropper, draw a fuel sample from competitor's tank or fuel line and fill test tube approximately 2/3 full. Always use a new pipette and a new test tube for each competitor.
1. Wearing protective latex or rubber gloves, carefully squeeze one drop of Germaine Reagent directly into the center of the fuel sample in the test tube. Do not allow reagent to run down the side of the test tube, as it makes reading the test more difficult.
NOTE: Most users will find the test easiest to read by holding the tube up at eye level when the reagent is added to make viewing any reaction more convenient.
2. When the Germaine reagent drop first hits the fuel sample, any oil dissolved and/or suspended in the gasoline will come out of solution and fall immediately to the bottom of the test tube. This is not a positive reaction. Different oils may react differently, but a single, fast falling drop of oil is typical.
3. The formation of a white or light brown precipitate (like little snowflakes) at the point where the Germaine Reagent hits the fuel sample is a positive indication of the presence of 1,4 dioxane. The precipitate will drift, depending on size and density, to the bottom of the test tube. Within a few minutes it will darken from contact with oil drops in the bottom of the tube.
4. It is always advisable to repeat a positive test to ensure that no error has been made.
5. It is good practice to carry a sample of known legal fuel and a sample of 1,4 dioxane to use as a verifying test. Simply make up 3 test tubes, one containing the known legal fuel, one containing known legal fuel to which you then add some 1,4 dioxane, and one containing the competitor's fuel. Then repeat the test, observing any reaction in the known legal sample, then the known legal sample containing 1,4 dioxane, and finally the competitor's sample. Having observed the reaction of the sample known to contain 1,4 dioxane, it will be easier to confirm the reaction in the competitor's sample.

CERIC NITRATE FUEL TEST

The purpose of this test is to determine if alcohol is present in a fuel sample.

The following is a list of special equipment necessary to perform the test.

- 50 ml graduated cylinder with subdivisions of 1.0 ml (or less)*
- 100 ml glass beaker*
- 18 mm x 150 mm clear glass test tube*
- 2-ounce glass dropper bottle with dropper assembly*

Following is a list of the chemicals necessary to perform this test:

- Ceric Ammonium Nitrate $(\text{NH}_4)_2\text{Ce}(\text{NO}_3)_6$*
- Nitric Acid (HNO_3) , 70%*

The reagent solution should be made prior to the race (within a couple of days and is done as follows:

- 1. Pour 41 ml of distilled water into the glass beaker.*
- 2. Carefully add 9.0 ml of Nitric Acid to the water in the glass beaker.*
- 3. Add 20 grams of Ceric Ammonium Nitrate to the solution in the glass beaker.*
- 4. Dissolve the Ceric Ammonium Nitrate by gently stirring. Slight heating of the solution will speed the process; however, DO NOT BOIL!*

Pour the Reagent Solution into the dropper bottle and secure the cap. The Reagent Solution should have a yellow color.

Recommended fuel test procedure:

- 1. Pour approximately 10 ml of the fuel sample into the test tube.*
- 2. Carefully add six (6) drops of the Reagent Solution to the fuel sample in the test tube.*
- 3. Seal the open end of the tube and invert several times.*
- 4. The Reagent Solution should accumulate at the bottom of the test tube. Observe the color of the accumulated Reagent Solution. If it is the same color (yellow) as the original solution in the dropper bottle, the fuel sample contains no alcohol. If the accumulated Reagent Solution in the test tube has changed from its original color (yellow), the fuel sample is not legal.*

MOD 125 OUTBOARD CLASS (Formerly 125CC)

Mod 125H, Mod 125R

Engine: PRD Fireball

Mod 125R – Formula A OMC engine (Approved 2024 - See Formula A OMC specifications)

SPECIFIC TECHNICAL RULES for Mod 125 Outboard

It is the intent of the Modified Outboard Commission that the engine in this class be raced as received from the manufacturer and the MORC, with the modifications as specifically allowed in these rules.

1. *Used Fireball engines are legal provided all specifications are met.*
2. *Any questionable part may be compared to a known legal part to determine legality.*
3. *The motor must have the “US” stamp on the crankcase.*
4. *Aftermarket starter Bendix cover and starter ring gear cover are permitted.*
5. *A starter switch affixed to the engine must have a shield to prevent accidental engaging of the starter. (2020 Commission).*
6. *Any length exhaust adapter may be used between the supplied header and supplied pipe. (2020 Ballot)*
7. *A 3/16” maximum hole may be drilled at the bottom of the end cap of the exhaust pipe to permit drainage of any trapped water.*
8. *Maximum Gear ratio to be 11:17*
9. *All on board starter switches must have a shield to prevent accidental engaging of the starter*

PERMISSIBLE MODIFICATIONS AND RESTRICTIONS for Mod 125 Outboard

THE SPECIFIC DIMENSIONS AND TOLERANCES LISTED BELOW COMBINED WITH THE ABOVE MODIFIED OUTBOARD SPECIFIC CLASS RULES ARE THE ONLY TECHNICAL LIMITATIONS TO BE PLACED ON THE ENGINE BY INSPECTORS. It is to be clearly understood that all engines, parts, etc. must comply with the dimensions and tolerances shown on the “Official Modified Outboard Specification Sheet”. In cases of conflict, the specific class rules shall apply.

- 1 *Any type or make of nut, bolt, screw, washer, spark plug, piston ring, propeller, ring pin, fuel line, fuel line fittings, starter plate, spacer plate assembly and ignition parts may be used **Any bearing, seal, gasket may be used - 2025 Clarification***
- 2 *Motors may be modernized with the use of parts manufactured for later model motors of the same class. However, if new parts differ from Modified Outboard specification sheets, approval of MORC is required. The interchange of parts from one motor to another in these classes is not permitted except where the manufacturer provides interchangeable parts.)*
- 3 *Any make or material fabricated motor driveshaft housing and any make or type of clamp and swivel bracket is permitted.*
- 4 *The addition of metal to any drive shaft housings and lower unit gear housings is permitted for the specific purposes of strengthening these parts.*

MOD 125 PRD OUTBOARD CLASS

- 5 *The addition of material for the specific purpose of installation of cavitation plates to drive shaft housings and spray shields and gas tanks to motors is permitted.*
- 6 *It is permitted to rotate the powerhead on the down housing.*
- 7 *It is not permissible to add material (including chrome plate) to cylinder walls.*
- 8 *Cylinder diameters may be bored, honed or ground to a maximum of 0.050" larger than the manufacturers mean dimension as listed under "G" in the motor specification sheets. Off center or slant boring of cylinders from normal stock center lines and perpendiculars is not permitted.*
- 9 *Broken or damaged parts may be repaired by welding or the use of plastic epoxy compounds, provided that all internal dimensions, contours and surfaces or parts are restored as closely as possible to original condition, within specifications. The inspector will pass repairs that meet the word and spirit of this rule and will disqualify engines from having repairs which are obviously intended to provide an unfair advantage.*
- 10 *Alterations to carburetor and fuel systems are permitted as follows:*
 - a). *The butterfly or idling needle must be altered as necessary for the automatic cut-off throttle to function properly.*
 - b). *Filters or fuel pressure regulators may be added to any fuel line.*
 - c). *Fuel line cooling units are permitted.*
- 11 *Two-piece driveshafts are permitted and modifications to adapt approved lower unit gear housing to driveshaft housings are permitted.*
- 12 *Lower unit gear housings may be reduced to measurements as shown on the motor specifications sheets.*
- 13 *There are no water pump specifications on Modified gear units.*
- 14 *It is permissible to tack weld repair any multiple piece crankshaft for the purposes of maintaining alignment.*

<i>Bore</i>	54.30 mm – Max.
<i>Stroke</i>	54.0 mm
<i>Minimum cc's</i>	10.0 cc
<i>Squish Band Diameter</i>	54.0 +/- 0.20 mm
<i>Cylinder Length</i>	87.2 +/- 0.020 mm
<i>Crankcase Length</i>	139.2 +/- 0.020 mm
<i>Split line length of Crankshaft Center to Cylinder Surface</i>	70.2 +/- 0.020 mm
<i>Rod Length (Center to Center)</i>	100 mm +/- 0.10 mm
<i>Rod Weight</i>	100 grams +/- 5 grams
<i>Piston Length Skirt to Edge of Crown</i>	58.8 +/- 0.070 mm
<i>Wrist Pinhole Center to Edge of Piston Crown</i>	29.8 +/- 0.070 mm
<i>Piston Weight</i>	135 grams +/- 5 grams
<i>Exhaust Port Height</i>	34.5 +/- 0.20 mm
<i>Transfer Port Heights</i>	43.6 +/- 0.50 mm
<i>Boost Port</i>	43.6 +/- 0.50 mm
<i>Gasket between Cylinder and Crankcase Thickness</i>	0.005 inch Minimum

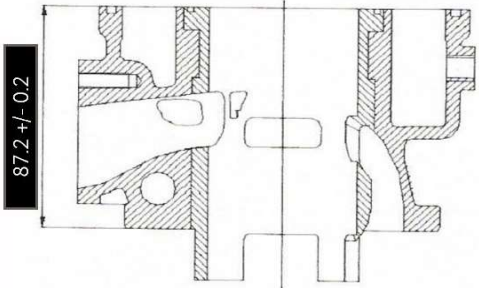
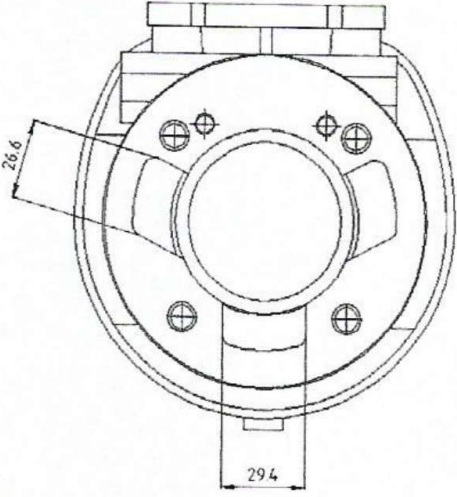
CYLINDER SECTION	CYLINDER BASE
 <p>A technical cross-section drawing of the cylinder assembly. It shows the internal components including the piston, connecting rod, and valves. A vertical dimension line on the left side indicates a length of 87.2 +/- 0.2.</p>	 <p>A technical top view drawing of the cylinder base. It shows a circular component with a central opening, four screws around the perimeter, and a mounting tab at the bottom. Two dimensions are provided: 26.6 for the width of the mounting tab and 29.4 for the diameter of the central opening.</p>

CRANKSHAFT

INTERIOR VIEW OF SUMP

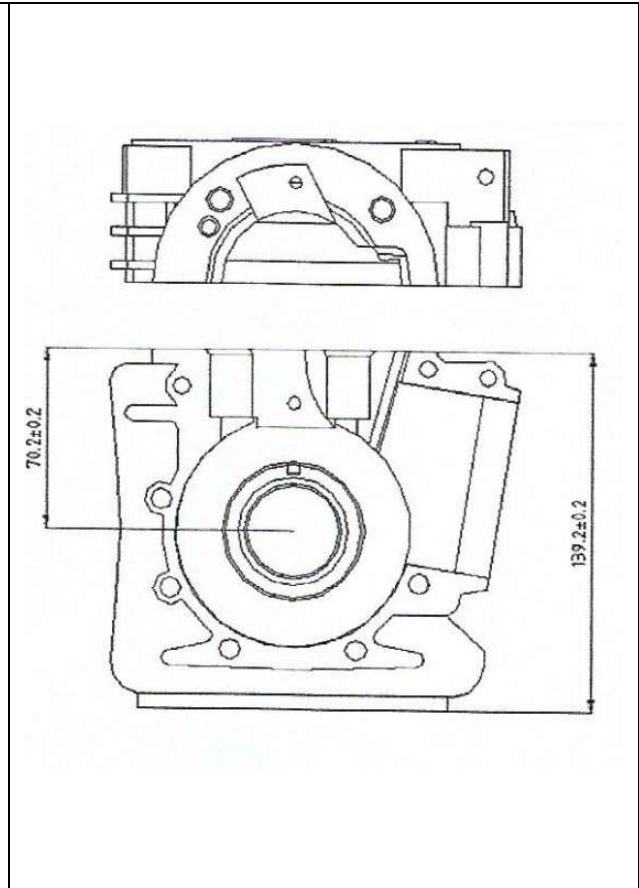
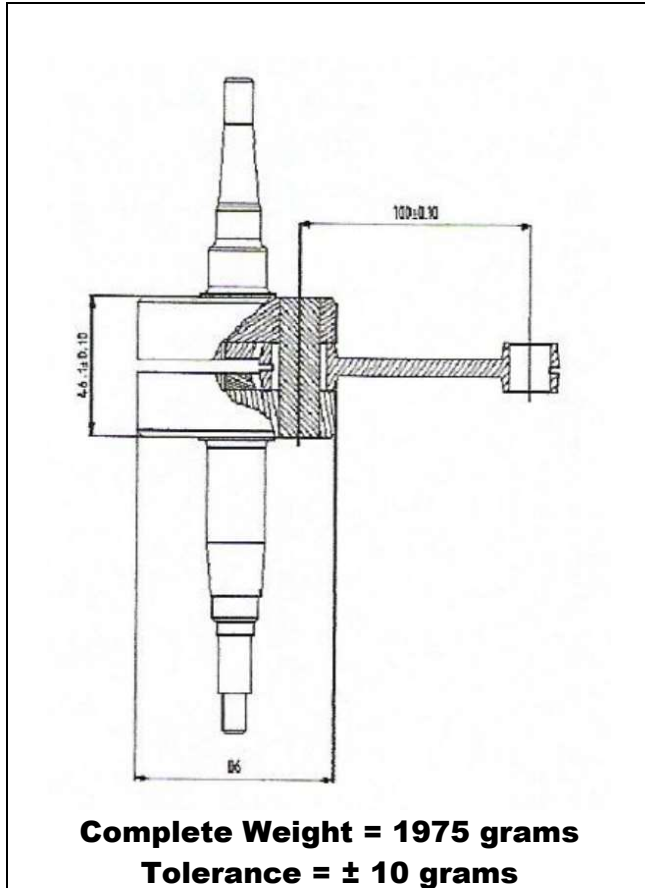

CYLINDER HEAD AND COMBUSTION CHAMBER

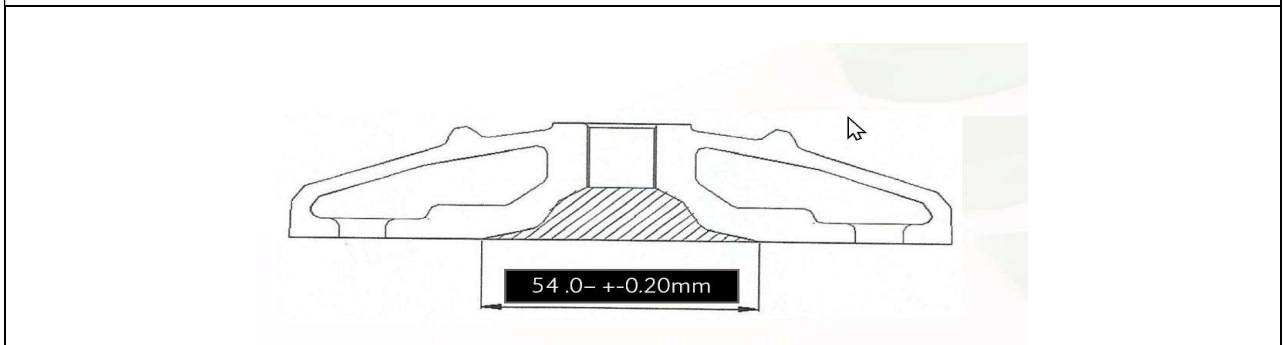

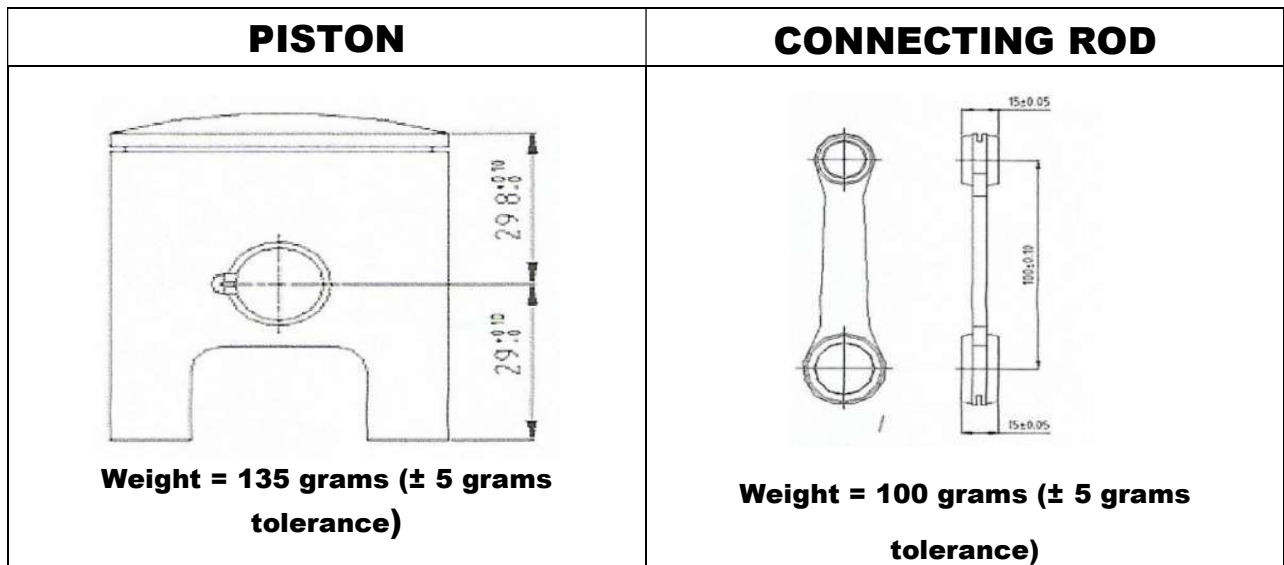
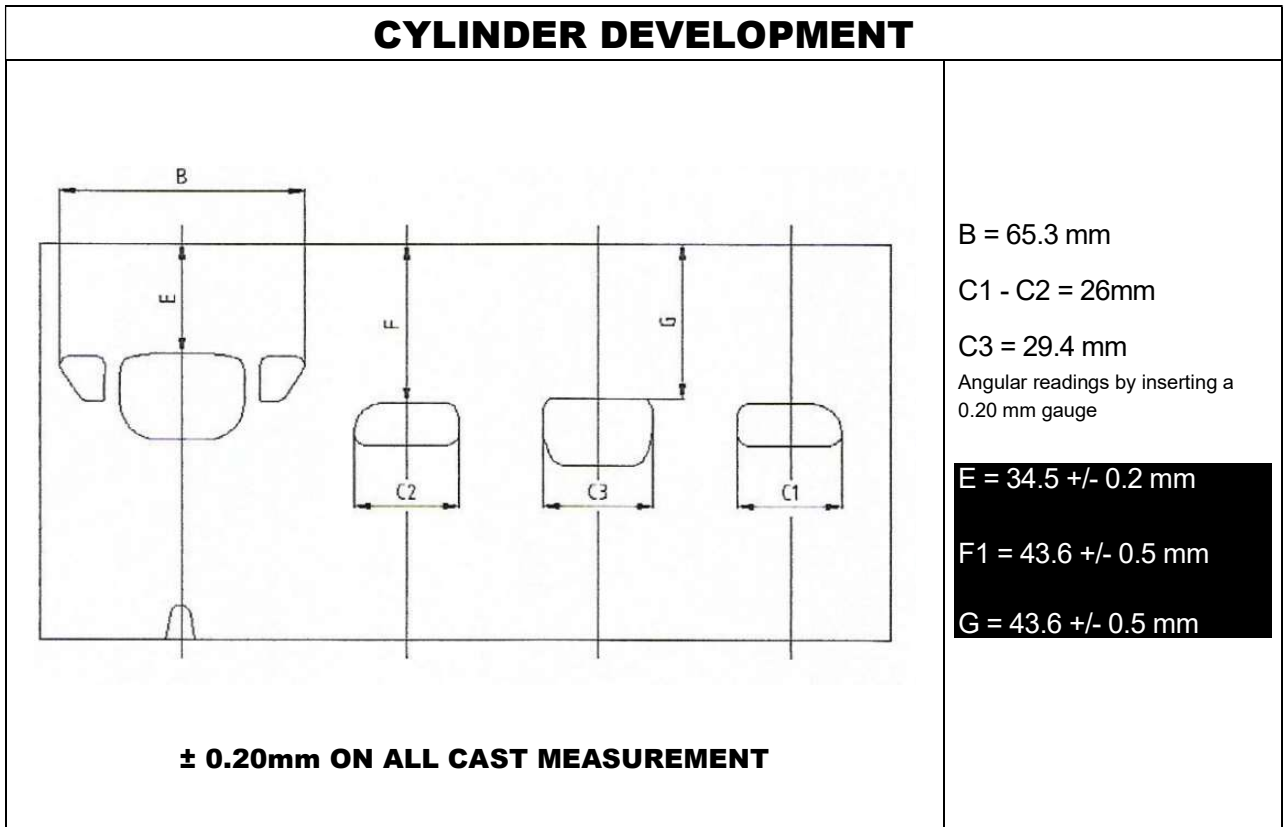

CARBURETOR DIMENSION

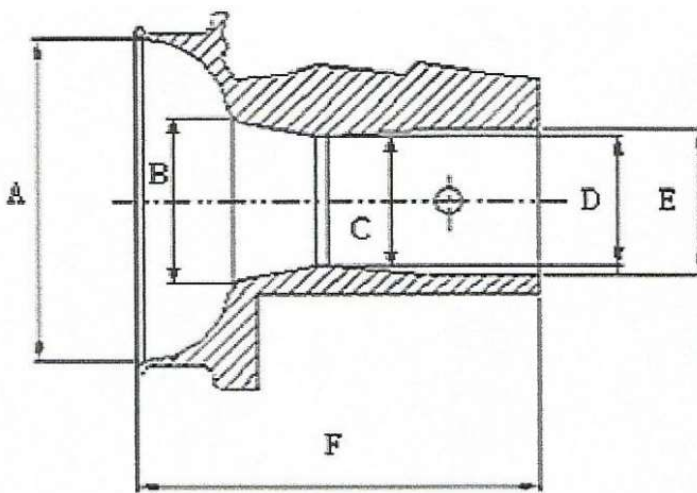

A – 33.75 mm
(±

C – 24.0mm
(±0.10mm tolerance)

D – 24.00mm
(±0.10mm tolerance)

E – 27.00mm
(±0.10mm tolerance)

F – 66.25mm
(±0.10mm tolerance)

DRAWING OF THE SILENCER AND ITS COMPONENTS

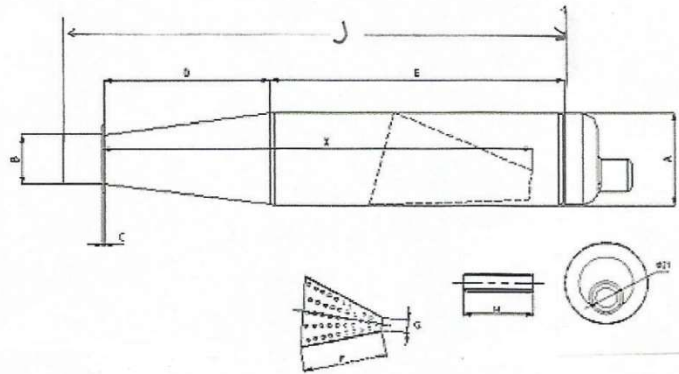

(±0.50 mm tolerance on all measurements)

Measurements

- A – 100 mm
- B – 54 mm
- C – 3 mm
- D – 170 mm
- E – 315 mm
- F – 170mm
- G – 21mm
- H – 135mm
- I – 455 mm
- J – 520mm

EXHAUST HEADER

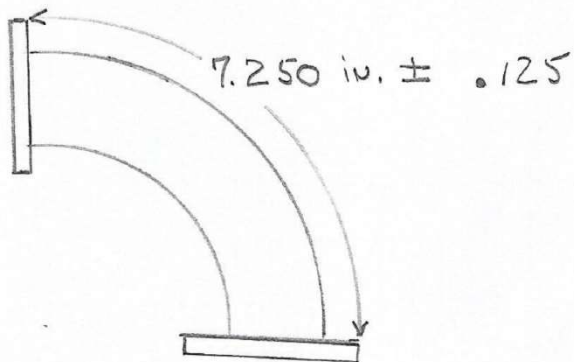

Formula A MODIFIED OUTBOARD CLASS (Formerly 200cc)

Formula AMH, Formula AMR

Engine – OMC Evinrude EKT, Johnson JKT

Engine – Mercury AX (in stock configuration) - Approved in Hydro class only.

See J Class rules for complete technical specifications

SPECIFIC TECHNICAL RULES for OMC FORMULA A MODIFIED OUTBOARD

It is the intent of the Modified Outboard Commission that the engine in this class be raced as received from the manufacturer, with the exception of modifications as specifically allowed in these rules.

1. *There shall be a minimum distance of 1.375" between the boat bottom and the prop shaft center line (at its aft end). The measurement of this height shall be "as raced" with the engine turned straight (prop shaft in-line with the fore-aft centerline of the boat). The bottom of the boat (as used in this rule) shall be the lowest planning surface at the back of the boat. This rule does not apply to boats running in Kilo trials.*
2. *The only legal engines for these classes are the Johnson and Evinrude model "KT".*
3. *The engine shall be operated with its upper and lower motor covers installed as originally supplied by the manufacturer. However, it is permissible to add a hole for "squirt can" priming.*
4. *Service parts for this model will be considered as legal replacement parts. This includes steering bracket bolts, steering bar bolts, gearcase bolts, connecting rod bolts, throttle plate screws, and cylinder head gasket. Other than listed here, any make nut, bolt, screw, washer, fuel line component, and adjustable high speed carburetor jet system is permissible. In addition, it is permissible to use after-market steering bars, brackets and tie bar, external carburetor linkage anchors, retainers, carb, bowl baffle, spark advance anchor, throttle cable anchor bracket and cable retainer, grommets and plugs for lower cowl as long as they are substantially the same as the OEM parts.*
5. *Larger or smaller fixed carburetor jets are permitted.*
6. *Any type or make spark plug is permitted.*
7. *The mounting of a fuel tank to the engine or steering bar is not permitted.*
8. *It is legal to have any engine bore configuration up to .040 oversize.*
9. *The addition or removal of material to or from the flywheel is not permitted.*
10. *Broken parts may be repaired by welding or with the use of plastic compounds. However, all contours and dimensions must remain within the requirements of these specifications.*
11. *It is permissible to repair stripped threads by tapping oversize, heli-coils, or threaded inserts.*
12. *Thrust brackets of any manufacturer are permitted.*

FORMULA A OMC OUTBOARD CLASS

13. *Steering bar brackets shall have their retaining bolts safety wired as supplied by the manufacturer. A powerhead may be fitted with double ended studs and attached to the drive housing and through the steering bar brackets and secured with washers and lock nuts.*
14. *The gearcase split line cavities shall be left as supplied by the manufacturer (i.e., unfilled).*
15. *It is permitted to remove the transom cleats, which are located in the transom surface of the stern bracket.*
16. *The engine must meet the requirements of the OMC inspection template part number 568050 for the gearcase.*
17. *The addition of extra ports or passages in the powerhead is not permitted.*
18. *Modifications of the powerhead (such as porting, balancing, media blasting, etc.) are permitted by REMOVAL of material only.*
19. *The exhaust passage in the gearcase must retain its original cast surface finish.*
20. *Material may not be added to the motor, with the following exceptions:*
 - A. *Rule # 13 above and Rule # 23 below.*
 - B. *The exhaust megaphone.*
 - C. *The specific features controlled by "D" and "D1" of the exhaust housing.*
21. *There shall not be any modification to the exhaust housing except to features "D" and "D1" of the exhaust housing.*
22. *The OEM exhaust megaphone must be used. However, it may be modified within the limits of these specifications. The exhaust megaphone must also be contained within the exhaust housing.*
23. *It is permissible to alter the water-cooling system on this engine. This includes but is not limited to the alteration of the water jackets by drilling additional water passages, plugging existing water passages, and by the addition of extra water tubes and outlet holes.*
24. *It is permissible to use aftermarket ignition components, pistons, piston rings, and engine seals, if the specifications are met. Any oversize piston that conforms to the E, F, and M dimension is approved so long as it is .040 oversize or smaller and so long as the piston crown (dome) configuration conforms to the OEM piston and the maximum bore specification is maintained.*

Note: *The piston crown and ring configuration on the Sierra/Napa/Dolphin .010, .020 & .030 oversize pistons as well as the oversize Wiseco piston are specifically approved. Due to some differences between ring designs on the after-market pistons, it should be clearly understood that the rings are not to be interchanged between pistons of different manufacturers.*

FORMULA A OMC OUTBOARD CLASS

25. *The driver shall be responsible for the condition of the engine as raced. Errors on the part of the manufacturer, mechanic or previous owner will not excuse noncompliance with the rules.*
26. *Reeds of any manufacture and material are permitted.*
27. *It is permissible to use thermal barrier coat piston crowns and piston skirts provided the overall piston and crown dimensions are not changed.*
28. *The outside surface of the gearcase may be either painted or unpainted. If it is painted, the color must be the same as the original factory motor color. If the gearcase is unpainted, any surface finish is acceptable.*
29. *Any non-OEM part for the 13.2 cu. in. OMC engine that conforms to the specifications in the Tech Manual for the Formula A Modified class is approved.*
30. *Any OEM part which was originally manufactured for the 13.2 cu. in. OMC engine regardless of the serial #, casting #, date of manufacture is approved so long as it conforms to the specifications in the Tech Manual for the Formula A Modified class.*
31. *Re-sleeving of the cylinders is permitted.*
32. *For Formula A modified hydros, two measurements for height are required. The aft end at the center of the propeller shaft and the forward end at the spit line of the gearcase. The maximum allowable height difference between these two measurements is 1/2". Note: The 1-3/8" propeller shaft height rule also applies.*
33. *Any make fuel pump is legal.*

PERMISSIBLE MODIFICATIONS AND RESTRICTIONS for FORMULA A OMC Mod CLASS

THE SPECIFIC DIMENSIONS AND TOLERANCES LISTED BELOW COMBINED WITH THE ABOVE MODIFIED OUTBOARD SPECIFIC CLASS RULES ARE THE ONLY TECHNICAL LIMITATIONS TO BE PLACED ON THE ENGINE BY INSPECTORS.

It is to be clearly understood that all engines, parts, etc. must comply with the dimensions and tolerances shown on the "Official Modified Outboard Specification Sheet". In cases of conflict, the specific class rules shall apply.

- 1 *Any type or make of nut, bolt, screw, washer, spark plug, piston ring, propeller, ring pin, fuel line, fuel line fittings. **Any bearing, seal, gasket may be used - 2025 Clarification***
- 2 *The addition of metal to any drive shaft housings and lower unit gear housings is permitted for the specific purposes of strengthening these parts.*
- 3 *It is permitted to rotate the powerhead on the down housing in all classes except 200 cc Modified.*
- 4 *It is not permissible to add material (including chrome plate) to cylinder walls.*
- 5 *Removal of material by drilling holes, etc., into combustion chambers for the purpose of introducing water in that area is prohibited.*

- 6 *Indexing of pistons is permitted with the tolerances as specified in the “E” and “EE” measurement for that specific engine.*
- 7 *Alterations to carburetor and fuel systems are permitted as follows:*
 - a). *The butterfly or idling needle must be altered as necessary for the automatic cut-off throttle to function properly.*
 - b). *Filters or fuel pressure regulators may be added to any fuel line.*
 - c). *Fuel line cooling units are permitted.*

FORMULA A OMC OUTBOARD CLASS

Engine Model		Johnson JKT, Evinrude EKT			
Minimum cc's at TDC to top of spark plug hole		13.5			
Number of Cylinders		2			
Displacement (cubic inch)		13.2			
Cylinder Bore Diameter		Standard		2.183 – 2.195	
		.040 Oversize		Max 2.235 oversize	
Crank stroke		J	1.752 - 1.768		
Rod Length		L	2.994 – 3.006		
Piston Dimensions		E	3.908 – 3.928		
		F	1.858 – 1.878		
		M	0.628 – 0.656		
PISTON RINGS		Number Per Piston		2	
		Material OMC		Cast Iron	
		Thickness		OMC Sierra/Napa/Dolphin	
				Upper	.066 - .070
				Lower	.060 - .064
				Wiseco	
		Upper	.056 - .060		
		Lower	.056 - .060		
		Design		OMC Sierra/Napa/Dolphin	
				Upper	Pressure Back
Lower	Rectangular				
Wiseco					
Upper	Pressure Back				
Lower	Pressure Back				
No. of Ports Per Cylinder		Transfer		3 Holes	
		Exhaust		3 Holes	
Port Height		Transfer	A	3.500 Maximum	
		Transfer	A3	3.500 Maximum	
		Exhaust	C	3.690 Maximum	
Cylinder Height		K	4.865 – 4.895		
Cylinder Width		K1	4.495 – 4.545		
Crankcase Height		K2	1.810 – 1.850		
Intake Manifold Height		1.015 – 1.065			
Reed Material		Any			
Flywheel Weight Lbs. (Minimum)		5 Lbs. 4 Oz.			
Carburetor		Throat .984 – 1.016			
		Venturi .859 - .891			
Megaphone Length		U	1.00 minimum		
		U1	1.00 Minimum		
Housing Relief Hole		.290 - .330 diameter			
Gear Ratio	14:19				
Q	11.350-11.750		Bearing Specifications:		
Q1	8.900 – 9.300				
R	2.050 minimum		1	Roller	
W	4.745 – 4.785		3	Ball	
W1	4.240 – 4.440		4	Roller w/retainer	
V	17.940 – 18.060		5	Roller	
			6	Roller	
			7	Roller/roller thrust	
			8	Roller/roller thrust	
			9	Roller/roller thrust	
S					

FORMULA A OMC OUTBOARD CLASS

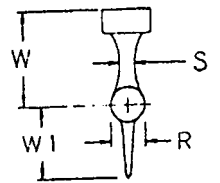
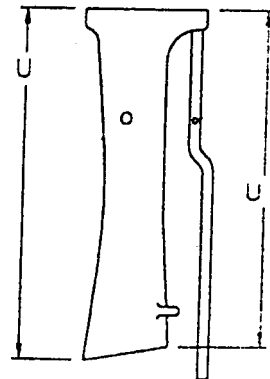
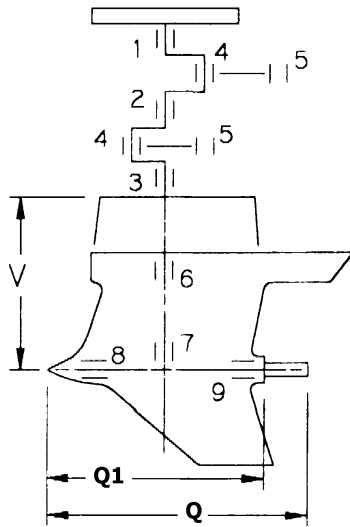
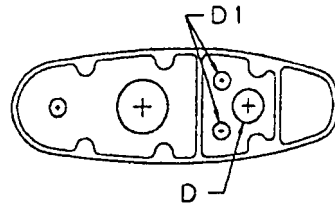
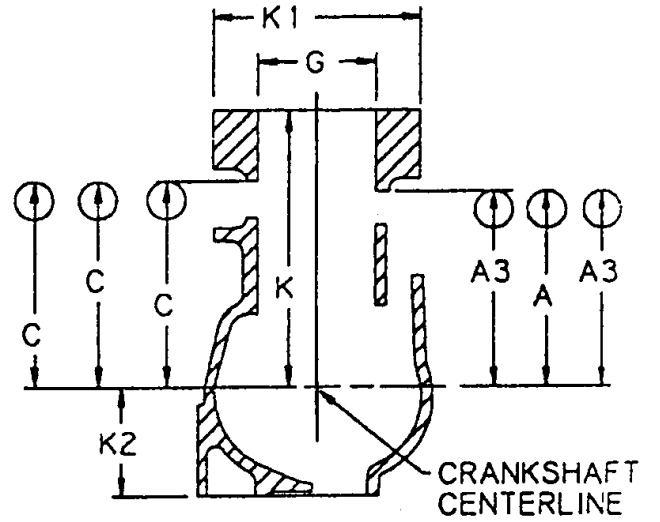
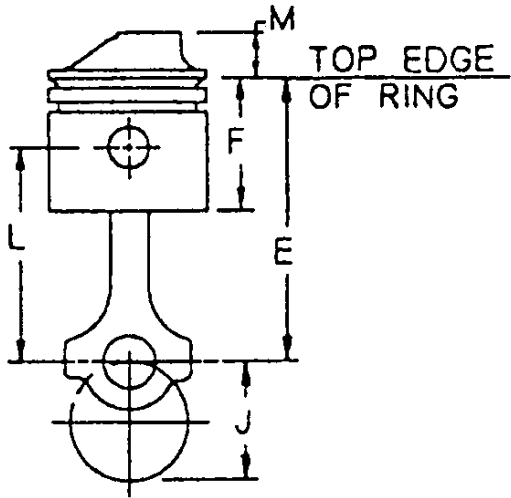

A MODIFIED OUTBOARD CLASS (Formerly 250cc)

AMH, AMR

Engine – 15 Hot Rod

15 Mercury KG4H / Mark 15 Series engine removed by class vote 2025)

SPECIFIC TECHNICAL RULES for CLASS A MODIFIED HOT ROD

1. *Main bearing bores in crankcases may be bored and fitted with bushings to provide a good fit on standard crankshaft main bearings. Alternatively, the crankcase may be bored to accept ball bearings, having oversize outside diameters but which are otherwise standard.*
2. *Any ignition may be used on any A Modified class engine.*
3. *Phelon service flywheels of cast construction (square top) such as Mark 25 Merc and Sweet 16 Champion shall not be used.*
4. *In no case shall the small taper bore flywheel (Hot Rod, KG4, etc.) Be machined out to fit on the larger taper crankshafts (MK20H, etc.).*
5. *Any approved two-cylinder carburetor may be used on any engine.*
6. *Float systems may be removed from Carter Model N carburetors and a return line installed.*
 - a) *Carter model N carburetors are approved for use on all 250 cc Modified class motors.*
 - b) *Material may be added to stiffen the float levers in Carter model N carburetors.*
 - c) *All KA model Tillotson carburetors having a 1" venturi and 1-1/8" throat are permitted for use on any A Modified class engine.*
7. *Any make deflector piston is permitted in A Modified class Hot Rod engines provided the measurements of the pistons comply with the motor specifications. The specified number and width of the ring grooves and the location of the top groove must be the same as on the factory replacement pistons.*
8. *Mercury fuel pumps and Tillotson KA carburetors are permitted for use on Hot Rod A Modified class engines. When necessary, adapters may be added to the crankcase front to provide the required intake diameter and stud pattern.*
9. *Due to the fact that the outer skin of the casting significantly contributes to the strength of the OMC aluminum flywheels furnished on A Modified class Hot Rods it shall not be permissible to alter them from the original supplied configuration.*
10. *Only the Hot Rod and **Sidewinder 15 / 20 lower** unit gear housing may be adapted to the A Modified class Hot Rod power heads.*
11. *Material may be added to the exterior of the Hot Rod cylinder block and crankcase for the purpose of re-enforcement. All machined surfaces, internal surfaces, contours, and dimensions must remain as close as possible to their original condition. Inspectors may rule out modifications that do not meet the spirit of this rule.*

12. *It is permissible to thermal barrier coat the piston crowns provided the overall piston and crown dimensions are not changed.*
13. *Any make fuel pump is legal.*
14. *For Hot Rod engines, it is permissible to add material to alter the cooling water flow or direction.*
15. *The Full Circle Hot Rod Field/ Moulder replacement crankshaft produced by Nathaniel Field and Thomas Moulder is legal in the A class.*

PERMISSIBLE MODIFICATIONS AND RESTRICTIONS for A HOT ROD / MERCURY MODIFIED OUTBOARD

THE SPECIFIC DIMENSIONS AND TOLERANCES LISTED BELOW COMBINED WITH THE ABOVE MODIFIED OUTBOARD SPECIFIC CLASS RULES ARE THE ONLY TECHNICAL LIMITATIONS TO BE PLACED ON THE ENGINE BY INSPECTORS. It is to be clearly understood that all engines, parts, etc. must comply with the dimensions and tolerances shown on the "Official Modified Outboard Specification Sheet". In cases of conflict, the specific class rules shall apply.

- 1 *Any type or make of nut, bolt, screw, washer, spark plug, piston ring, propeller, ring pin, fuel line, fuel line fittings, starter plate, spacer plate assembly and ignition parts may be used. **Any bearing, seal, gasket may be used - 2025 Clarification***
- 2 *The removal of integral gas tanks, spray shields, protective cowlings, spark plug protectors, compression release valves, fuel filters, starters and their mechanisms and carburetor chokes is permitted.*
- 3 *Motors may be modernized with the use of parts manufactured for later model motors of the same class. However, if new parts differ from Modified Outboard specification sheets, approval of MORC is required. The interchange of parts from one motor to another in these classes is not permitted except where the manufacturer provides interchangeable parts. Crankcase assemblies, for service use or stock racing, with 2.125 stroke, are to be considered interchangeable in the A and B Modified classes.*
- 4 *Open exhaust and special built or tuned exhaust systems are permitted. The addition of material to seal filler blocks and plug water outlets in blocks is permitted. Any new engines approved for use in the Modified category are not allowed to use open megaphone type exhaust systems.*
- 5 *Any make or material fabricated motor driveshaft housing and any make or type of clamp and swivel bracket is permitted.*
- 6 *The addition of metal to any drive shaft housings and lower unit gear housings is permitted for the specific purposes of strengthening these parts.*

- 7 *The addition of material for the specific purpose of installation of cavitation plates to drive shaft housing and spray shields and gas tanks to motors is permitted.*
- 8 *It is permitted to rotate the powerhead on the down housing in all classes except Formula A Modified.*
- 9 *It is not permissible to add material (including chrome plate) to cylinder walls.*
- 10 *Re-sleeving of cylinders is permitted.*
- 11 *Cylinder diameters may be bored, honed or ground to a maximum of 0.050" larger than the manufacturers mean dimension as listed under "G" in the motor specification sheets. Off center or slant boring of cylinders from normal stock center lines and perpendiculars is not permitted.*
- 12 *Broken or damaged parts may be repaired by welding or the use of plastic epoxy compounds, provided that all internal dimensions, contours and surfaces or parts are restored as closely as possible to original condition, within specifications. The inspector will pass repairs that meet the word and spirit of this rule and will disqualify engines having repairs which are obviously intended to provide an unfair advantage.*
- 13 *Material may be added to or removed from flywheels for balance purposes. Service engine flywheels may be machined down to racing size and weights, provided the weight of such flywheel is not reduced to less than the minimum specified for that class engine. Flywheels must not be interchanged between classes unless specifically intended by the original engine manufacturer.*
- 14 *Removal of material from non-reciprocating parts (pistons and rod assemblies are classified as reciprocating) is permitted except as noted in these rules and specification sheets.*
- 15 *Removal of material from reciprocating parts, except for balancing and polishing is prohibited except where permitted in these rules and specification sheets.*
- 16 *The polishing of moving parts and passages is permitted except where prohibited by individual class rules and specification sheets.*
- 17 *Beveling of crankshafts is permitted except where removal of material is prohibited by individual class rules and specification sheets.*
- 18 *No extra ports or passageways are allowed in the powerhead except where permitted in individual class rules and specification sheets.*
- 19 *Enlarging of intake and exhaust ports is permitted except where prohibited by individual class rules and specification sheets.*
- 20 *Removal of material by drilling holes, etc., into combustion chambers for the purpose of introducing water in that area is prohibited.*

- 21 *Indexing of pistons is permitted with the tolerances as specified in the “E” and “EE” measurement for that specific engine.*
- 22 *The addition of material for any purpose is prohibited except as noted:*
- a) *Elsewhere in these modified rules specifically.*
 - b) *Addition of material to the outside of piston skirts is approved, specifically meaning “coating” of skirts OD with a material to increase diameter.*
 - c) *Primers may be added and gas fittings installed in any carburetor or reed cage area. It is not permitted to use this as an accelerator pump or power jet.*
 - d) *Addition of thermal barrier coatings to piston crowns is approved. However crown dimensions must remain as manufactured.*
- 23 *Alterations to carburetor and fuel systems are permitted as follows:*
- a) *For marathon use, an auxiliary fuel supply connection may be added to the carburetor.*
 - b) *The butterfly or idling needle must be altered as necessary in order for the automatic cut-off throttle to function properly.*
 - c) *Adapters or extra length high-speed needles are permitted.*
 - d) *Any inlet needle and seat may be used in any carburetor.*
 - e) *Material may be added to stiffen float levers in Carter model N carburetors.*
 - f) *Filters or fuel pressure regulators may be added to any fuel line.*
 - g) *All KA model Tillotson carburetors having a one-inch venturi are legal for use on all class A, B, and D Modified engines provided they measure within KA7A model specifications and the use of adjustable high-speed needles and seats from KA7A carburetors and conversion kit no. 2619A1 is permitted.*
 - h) *Fuel line cooling units are permitted.*
- 24 *Two-piece driveshafts are permitted and modifications to adapt approved lower unit gear housing to driveshaft housings are permitted. (2024 rule #26 – Permissible Modifications and restrictions)*
- 25 *Lower unit gear housings may be reduced to measurements as shown on the motor specifications sheets. The addition or removal of material on gear cases is permitted as long as “R” and “S” dimensions are maintained.*
- 26 *There are no water pump specifications on Modified gear units.*
- 27 *After-market pistons are permitted for use in all classes. However, they must meet all specifications for the class.*
- 28 *Any make fuel pump is legal on any Modified motor.*

A MODIFIED OUTBOARD CLASS
Hot Rod

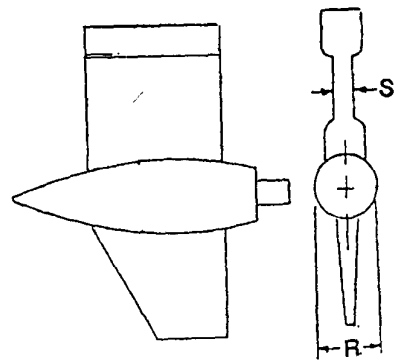
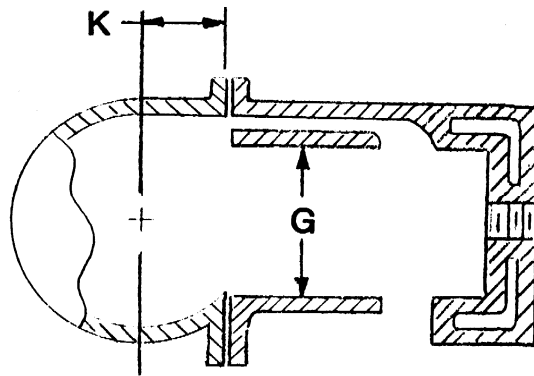
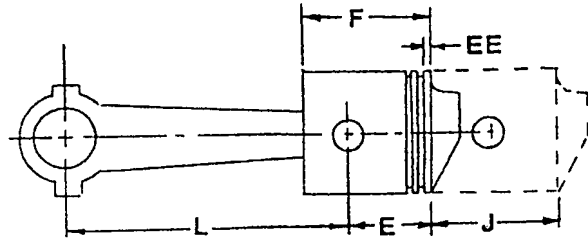

A MODIFIED OUTBOARD CLASSHot Rod

CLASS	A Mod	A Mod
ENGINE	HOT ROD	MERCURY 15
Minimum CC's to top of plug Hole	11.0	
EE	.125 - .250	
E	1.125 - 1.250	
F	2.00 - 2.125	
G	2.116 - 2.216	Engine removed From A Mod Class
J (STROKE)	1.999 - 2.046	Engine removed From A Mod Class
K	1.812 - 1.874	
L	3.547 - 3.577	
R/S Minimum	2.063/.750	Engine removed From A Mod Class
Piston weight w/rings pin & fastener	6 oz.	
Number & Thickness of Rings	Two - .062 or Two - .046	
Rod Weights w/ Bearings Screws & Spacers	5 oz.	
Rotary Valve Opens	1.844 - 1.968 from TDC	
Rotary Valve Closes	.562 - .812 from TDC	
Carburetors	See Following List	Engine removed From A Mod Class
Number of Intake Ports per cylinder		Engine removed From A Mod Class
Number of exhaust Ports per cylinder		Engine removed From A Mod Class
Gear Ratio	14:15 or 14:19	Engine removed From A Mod Class

A Modified Hot Rod Carburetor

CARBURETOR	VENTURI +/- .016 unless otherwise specified	THROAT +/- .016 unless otherwise specified
Tillotson HL & CR1A	7/8"	1"
Tillotson AJ49 & 51	13/16"	61/64" x 1-3/32"
Tillotson KA	1"	1-1/8"
Tillotson HR	1-9/32"	1-3/8"
Carter Model N	15/16"	1-5/16"
WR6	1-9/32 +/- 1/16"	1-3/8 +/- 1/16"
WRC1	1" +/- 1/16"	1-5/16" +/- 1/16"
Lectron 30, 32, 34	N/A	30 mm, 32 mm, 34 mm

A MODIFIED OUTBOARD CLASS (Formerly 250cc)

AMH, AMR

Engine – 20 cu in Mercury (20H) – In 1987 stock outboard specifications

SPECIFIC TECHNICAL RULES for A MERCURY - Mark 20H

1. No Polishing or balancing is permitted
2. The rewind starter must be in place. It shall be permissible to use a MARK 25 rewind assembly and related parts. Any type of bracket is permissible to attach rewind assembly to powerhead assembly.
3. The MARK 25 and MARK 25 electric crankcase, crankshaft, reed block (with 1" x 5/8" holes) and cylinder block may be used interchangeably with MARK 20-H parts. No modification of the MARK 25-cylinder block is permitted. The crankcase and reed block carburetor opening may be machined to duplicate the MARK 20-H crankcase opening dimension. An adapter may be added to the front of the MARK 25 crankcase to facilitate the installation of a 20-H carburetor. The distance from the carburetor mounting surface to the inside of the crankcase shall be no greater than the corresponding distance on the Mark 20-H crankcase.
4. The reed blocks with 5/8" x 1-7/32" openings are not allowed. The only reed blocks allowed have 5/8" x 1" openings. It is allowable to machine the sand cast C and D and MARK 25 reed blocks with the 1" x 5/8" openings to receive the 20-H center main bearing race. The reed block may be drilled and tapped for the reed block bolt in another location other than the original location. The crankcase may be drilled for a reed block bolt through the fuel pump boss.
5. The "stuffed" crankcases are not permissible.
6. All A Mod, B Mod, and 25 SS Mercury gear cases are legal if they meet specifications.
7. Any KA series carburetor can be used as long as the venturi stays at 1" and the throat diameter at 1-1/8". This includes the KA3A, KA2A, KA1A, and KA7A, and any needle and seat from the KA7A is legal. Any model N Carter carburetor is legal with the 15/16" venturi and a 1-5/16" throat.
8. It is permissible to put a new keyway in the flywheel for repair. It must be 180° opposite the existing keyway. The flywheel must meet specifications.
9. It is permissible to mill or file the exhaust filler block for a good fit to the block. It is permissible to seat the filler block in a sealing or bedding compound to seal it to the block. The "Fickett" filler block is a legal replacement part.
10. For purposes of repair of welded blocks and crankcases only the following will be allowed:
 - a) A metal shim and appropriate gaskets may be added to the crankcase to bring the K dimension of the repaired crankcase within specification.
 - b) A metal shim and appropriate gaskets may be added to the repaired block to bring the port dimensions within specifications. All shims and gaskets must duplicate the dimensions of the block to crankcase gasket except thickness. The 1/32" gasket must be retained.
11. Any rod of the same manufacturer is permissible that meets the "L" dimension and minimum weight.
12. Curve port covers are not allowed.
13. Lower units are to be painted.
14. Any fuel pump is legal.
15. The Phelon ignition can be replaced with the OMC CD2 system utilizing the OKMC cast steel flywheel PN 584584 / CN 513972 prepared in the same manner as the Sidewinder / Hot Rod OMC flywheel 584222. The flywheel must meet the existing rule weight. No modification of the crankcase or block is allowed. The flywheel must be machined by an approved modified source.
16. It is permissible to use the 20-cu. in. Mercury engine with 1987 stock outboard powerhead specifications with expansion chamber exhaust or 20-H conversion exhaust with a quicksilver lower unit in the AMOD class.

20 cu (Mark 20H) Mercury in A MOD with 1987 Stock Specs

Displacement	19.8	
Number of Cylinders	2	
Gear Ratio	15-15,16-21	
Minimum Compression Volume in cc's top of plug hole	17 cc's	
Carburetors KA1A, KA2A, KA3A, KA7A Carter Model N	Venturi +/- .016 1" 15/16	Throat +/- .016 1-1/8 1-5/16
A	2.246 - 2.266	
A1	1.516 - 1.546	
C	2.461 - 2.481	
C1	1.735 - 1.765	
E-E	1.700 - 1.740	
F	2.781 - 2.843	
G	2.438 - 2.472	
J	2.110 - 2.129	
K	1.804 - 1.824	
L	3.713 - 3.725	
Q	11-1/4	
R	2-1/8 +/- 1/32	
S	1 +/- 1/32	
Number and Size of Openings In Reed Block	8 Oval Ports 1 x 5/8	
Reed Material	Steel, Fiberglass	
Reed Thickness (Steel)	.012 (Steel only)	
Reed Stop Height	.125 - .187	
Piston Weight w/Rings, Wrist pins, & fastenings	7.5 oz. Min.	
Weight of Conn. Rod W/bearings in both ends & thrust washers	6.75 oz. Min.	
Weight of flywheel	4.5 lbs. Min.	

A MODIFIED OUTBOARD CLASS
Mercury 20H in Sock Configuration

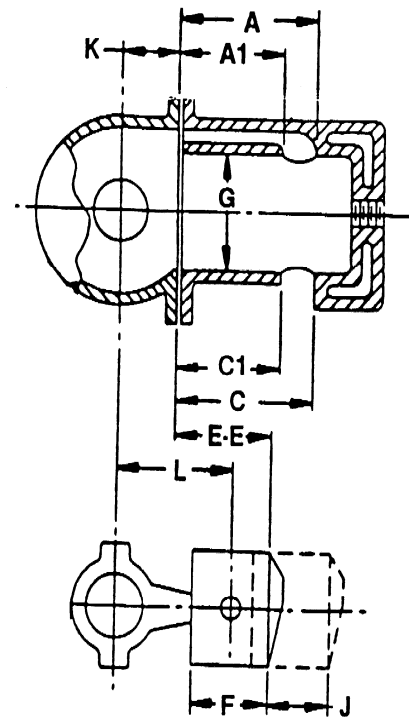
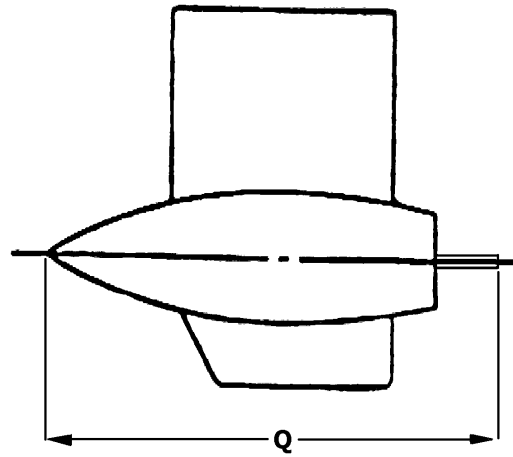
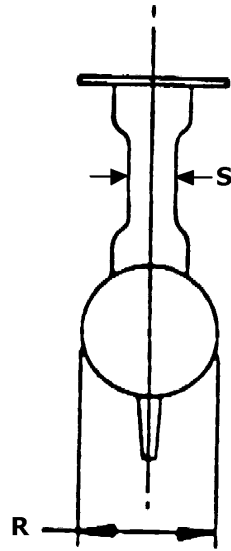

A MODIFIED OUTBOARD CLASS (Formerly 250CC)

AMH, AMR

Engine – Sidewinder 15S /15H

SPECIFIC TECHNICAL RULES for CLASS A SIDEWINDER OUTBOARD

1. *Main bearing bores in crankcases may be bored and fitted with bushings to provide a good fit on standard crankshaft main bearings. Alternatively, the crankcase may be bored to accept ball bearings, having oversize outside diameters but which are otherwise standard.*
2. *Any ignition may be used on any A Modified class engine.*
3. *Phelon service flywheels of cast construction (square top) such as Mark 25 Merc and Sweet 16 Champion shall not be used.*
4. *In no case shall the small taper bore flywheel (Hot Rod, KG4, etc.) be machined out to fit on the larger taper crankshafts (MK20H, etc.).*
5. *Any listed two-cylinder carburetor may be used on any engine.*
6. *Float systems may be removed from Carter Model N carburetors and a return line installed.*
 - a) *Carter model N carburetors are approved for use on all A Modified class motors.*
 - b) *Material may be added to stiffen the float levers in Carter model N carburetors.*
 - c) *All KA model Tillotson carburetors having a 1" venturi and 1-1/8" throat are permitted for use on any A or B Modified class engine.*
7. *Any make deflector piston is permitted in A Modified class Hot Rod engines provided the measurements of the pistons comply with the motor specifications.*
8. *Mercury fuel pumps and Tillotson KA carburetors are permitted for use on Hot Rod A Modified class engines. When necessary, adapters may be added to the crankcase front to provide the required intake diameter and stud pattern.*
9. *Due to the fact that the outer skin of the casting significantly contributes to the strength of the OMC aluminum flywheels furnished on the A Modified class Hot Rods, it shall not be permissible to alter them from the original supplied configuration.*
10. *Only the Hot Rod or Sidewinder lower unit gear housing may be adapted to A Modified class Sidewinder power heads.*
11. *All machined surfaces, internal surfaces, contours, and dimensions must remain as close as possible to their original condition. Inspectors may rule out modifications that do not meet the spirit of this rule.*
12. *It is permissible to thermal barrier coat the piston crowns provided the overall piston and crown dimensions are not changed*

A MODIFIED OUTBOARD CLASS
Sidewinder Engine

13. Any make fuel pump is legal.
14. For Sidewinder engines, it is permissible to add material to alter the cooling water flow or direction.
15. Timing, carburetor jets, metering rods may be adjusted or changed. Adjustable main jets and needle valves are legal. No other modifications to the carburetor are legal.
16. Cylinder head combustion chamber. The cylinder head combustion chamber is cast, it is permissible to clearance the corners of the chamber to prevent contact with the piston deflector and the head.
17. Cylinder head gasket. The cylinder head gasket may be either a machined aluminum plate gasket or a Hot Rod style head gasket. The gasket has 3 3/16" holes in the top and a 1 1/16" hole in the bottom. The aluminum gasket may be o ringed. Both gasket types are legal if cc specifications are met.
18. Permissible Modifications and Restrictions printed in the front of the Technical Manual that are applicable to Hot Rod motors are also legal for Sidewinder motors.
19. Sidewinder motors must use a closed or quiet exhaust. No open pipes are permitted

A Modified Sidewinder Carburetor Chart

CARBURETOR	VENTURI +/- .016 unless otherwise specified	THROAT +/- .016 unless otherwise specified
Tillotson HL & CR1A	7/8"	1"
Tillotson AJ49 & 51	13/16"	61/64" x 1-3/32"
Tillotson KA	1"	1-1/8"
Tillotson HR	1-9/32"	1-3/8"
Carter Model N	15/16"	1-5/16"
WR6	1-9/32 +/- 1/16"	1-3/8 +/- 1/16"
WRC1	1" +/- 1/16"	1-5/16" +/- 1/16"
Lectron 30, 32, 34	N/A	30 mm, 32 mm, 34 mm
Delardo VHST28	N/A	28
Delardo PHBG21	N/A	21

A MODIFIED OUTBOARD CLASS
Sidewinder Engine

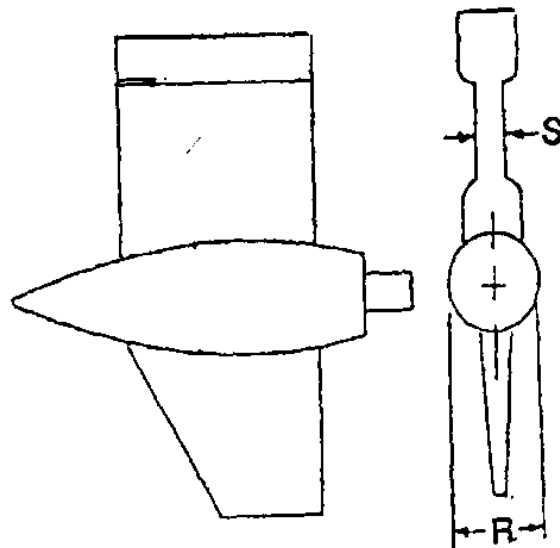
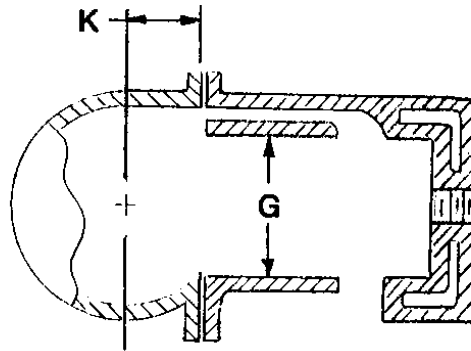
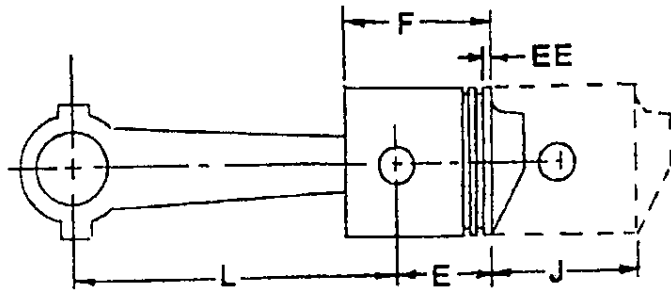

A MODIFIED OUTBOARD CLASS
Sidewinder Engine

CLASS	A Modified	Notes/Description
ENGINE	Sidewinder 15S and 15H	
Minimum cc's to top of plug hole	11.0	
EE		
E	1.125 – 1.250	Wrist Pin Center to Timing Edge
F	2.00 – 2.125	
G	2.062 – 2.162	Bore
J (Stroke)	1.999 – 2.046	
K	1.812 – 1.874	Crankcase Height
L	3.547 – 3.577	Rod Length
R/S Minimum	2.050/ .0750	
Piston weight w/rings, pin & fastener	6 oz.	
Number & thickness of rings	Two	
Carburetors	One from List Above	
Number of Intake Ports per Cylinder		
Number of Exhaust Ports per Cylinder		
Gear Ratio	14:15 or 14:19	

B MODIFIED OUTBOARD CLASS (Formerly 350CC)

BMH, BMR

Engine – Y-80 Yamato

SPECIFIC TECHNICAL RULES for B Modified YAMATO OUTBOARD

This powerhead shall be raced as furnished by the manufacturer along with the stock gear housing with a 14:16 ratio. Specification sheets are for reference only and not intended as a guide for blueprinting. The spirit of the rule is for the internal parts to remain stock with only these modifications allowed. Any OEM part in question may be compared to a new part enabling inspection to discern legality.

- 1. Only OEM parts are allowed except where specifically allowed in these rules.*
- 2. Any type or make of spark plug, gasket, bearing, seal, ignition component, propeller, piston ring, external nut, bolt, washer, and driveshaft housing may be used provided other parts are not altered to accommodate them.*
- 3. Only the following material may be removed: Gas tank, tank brackets, any or all of the cowlings, standard exhaust system, fuel lines and fittings, clamp brackets, and driveshaft housing. It is allowed to remove the carburetor spray shield mounting lugs and the removal of the spark advance handle on the magneto.*
- 4. Any propeller shaft is permitted. Diameters may be altered, and shear pin holes may be drilled or relocated. However, only one shear pin hole is permitted.*
- 5. Only the following material may be added: Any type of spray shield, (carburetor intake turning is prohibited), spark plug shield, throttle controls, kill switch hookup, chamber supports and controls, expansion chamber or tuned muffler, fuel pump, fuel filter, fuel pressure regulator, fuel lines and fittings, ignition advance and/or lockdown (provided that other parts are not altered to accommodate them).*
- 6. Any swivel, clamp brackets and tilt pin are permitted.*
- 7. All water plumbing modifications to move and/or vent water shall be off and through the exhaust stack plate. Water-cooled filler blocks are permitted however no modifications may be made to the motor block to accommodate these. Additional water vents off of the top of the stack plate are permitted and sealers may be used to seal the base of the filler block. It is permitted to bring extra water into the block via the stack plate and a water pickup attached to the boat. It is not permissible to block any water passages in the block to reroute water, etc.*
- 8. It is permitted to use the stock tuned exhaust system and it may be modified within the above rules.*
- 9. No open or open tuned exhaust stacks or megaphones are permitted. The intent of this is to keep the noise reduced in this class.*
- 10. The oversize pistons provided by the manufacturer and approved OEM are permitted – (See rule #24).*

B MODIFIED OUTBOARD CLASS
Yamato Engine

11. *Either the 14 mm or 18 mm head is permitted.*
12. *Holes may be drilled into the mag. Plate, coil plate, and end cap to drain water and holes may be filled, drilled, and tapped, etc.*
13. *There are no measurements on the reed port size in the OEM reed cage, however no alterations are allowed to the cage, reed, or shim and they must remain stock OEM parts.*
14. *Any make drive shaft housing of any length is allowed. The powerhead may be rotated provided the power head is not altered to accomplish this. A boat pitot water pickup may be used to feed water into the powerhead cooling system. Water lines, inlets, and outlets may be plugged and/or added. If the stock drive shaft housing is used it may be altered in any way provided that the spirit of rule 9 is not violated.*
15. *It is permitted to alter the shape and size of the gear housing by addition or removal of material, internally or externally. "R & S" dimensions must be maintained but no other dimensions apply. You may alter the housing to include a water pickup in the nose.*
16. *It is permissible to mill the cylinder head. Motors must meet the cc specifications. No combustion chamber shape or configuration changes except for volume are permitted. It is allowable to machine the squish band on both Model 80-cylinder heads (18mm and 14mm) provided the new dimensions H equals 2.335 – 2.365 and H1 equals 13 degrees min – 17 degrees max angle are adhered to. It is not permitted to remove any of the squish band from the head. A detectable edge must surround the squish band.*
17. *Top fill and/or "float less" carburetors are permitted, provided that the carburetor body is not altered in any way (i.e. filing, drilling, sanding, or polishing).*
18. *It is permissible to notch, drill or slot the top and bottom ends of the connecting rod at the crankshaft end of the rod for the purpose of improved lubrication.*
19. *It is permissible to use repaired or "after-market" crank pins and bearings so long as the stroke and other specifications are maintained.*
20. *Internal machine surfaces may be re-machined if minimum and maximum dimensions are maintained. Cast surfaces must remain as cast with no alterations, abrasive blasting or polishing. Note: It is not permissible to re-machine surfaces that do not have specific dimensions.*
21. *Aftermarket cylinder sleeves for the Yamato 80-M are legal provided the sleeves meet all applicable Yamato 80-M B MOD Class Specifications.*
22. *Aftermarket gear set with the same 14:16 ratio is legal. The pinion gear must have 14 teeth, and the propeller shaft gear must have 16 teeth.*
23. *The Yamato 302 gear housing using 14:15 or 14:16 underdrive and meeting the R specification of 2.250 minimum is legal in B Class. Internal machine work to accommodate gear set is specifically allowed.*

B MODIFIED OUTBOARD CLASS
Yamato Engine

24. *The standard Wiseco piston p/n 10186M06008 is legal for the Yamato 80-M. The oversize Wiseco piston p/n 10186M06046 (.015 over) and oversize Wiseco piston p/n 10186M06085 (.030 oversize) are legal for the Yamato 80-M. All aftermarket Wiseco Yamato 80 pistons available from Tom Johnston Yamatos.*
25. *Aftermarket ignition coils may be mounted in any location external to the OEM location. The addition of coil mounting brackets or coil mounting plates must not require internal modifications to the powerhead.*
26. *The aftermarket ignition system developed by Kyle Roskowski is legal on a B Yamato engine. Flywheel weights are to be the same as the current B Yamato engine.*

PERMISSIBLE MODIFICATIONS AND RESTRICTIONS for B MODIFIED YAMATO

THE SPECIFIC DIMENSIONS AND TOLERANCES LISTED BELOW COMBINED WITH THE ABOVE MODIFIED OUTBOARD SPECIFIC CLASS RULES ARE THE ONLY TECHNICAL LIMITATIONS TO BE PLACED ON THE ENGINE BY INSPECTORS. It is to be clearly understood that all engines, parts, etc. must comply with the dimensions and tolerances shown on the "Official Modified Outboard Specification Sheet". In cases of conflict, the specific class rules shall apply.

- 1 *Any type or make of nut, bolt, screw, washer, spark plug, piston ring, propeller, ring pin, fuel line, fuel line fittings, starter plate, spacer plate assembly and ignition parts may be used. **Any bearing, seal, gasket may be used - 2025 Clarification***
- 2 *The removal of integral gas tanks, spray shields, protective cowlings, spark plug protectors, compression release valves, fuel filters, starters and their mechanisms and carburetor chokes are permitted.*
- 3 *Motors may be modernized with the use of parts manufactured for later model motors of the same class. However, if new parts differ from Modified Outboard specification sheets, approval of MORC is required. The interchange of parts from one motor to another in these classes is not permitted except where the manufacturer provides interchangeable parts.*
- 4 *Any make or material fabricated motor driveshaft housing and any make or type of clamp and swivel bracket is permitted.*
- 5 *The addition of metal to any drive shaft housings and lower unit gear housings is permitted for the specific purposes of strengthening these parts.*
- 6 *The addition of material for the specific purpose of installation of cavitation plates to drive shaft housings and spray shields and gas tanks to motors is permitted.*
- 7 *It is permitted to rotate the powerhead on the down housing.*
- 8 *It is not permissible to add material (including chrome plate) to cylinder walls.*
- 9 *Re-sleeving of cylinders is permitted.*

- 10 *Cylinder diameters may be bored, honed or ground to a maximum of 0.050" larger than the manufacturers mean dimension as listed under "G" in the motor specification sheets. Off center or slant boring of cylinders from normal stock center lines and perpendiculars is not permitted.*
- 11 *Broken or damaged parts may be repaired by welding or the use of plastic epoxy compounds, provided that all internal dimensions, contours and surfaces or parts are restored as closely as possible to original condition, within specifications. The inspector will pass repairs that meet the word and spirit of this rule and will disqualify engines having repairs which are obviously intended to provide an unfair advantage.*
- 12 *Indexing of pistons is permitted with the tolerances as specified in the "E" and "EE" measurement for that specific engine.*
- 13 *The addition of material for any purpose is prohibited except as noted:
a) Elsewhere in these modified rules specifically.
b) Addition of material to the outside of piston skirts is approved, specifically meaning "coating" of skirts OD with a material to increase diameter.
c). Addition of thermal barrier coatings to piston crowns is approved. However crown dimensions must remain as manufactured.*
- 14 *Alterations to carburetor and fuel systems are permitted as follows:
a). For marathon use, an auxiliary fuel supply connection may be added to the carburetor.
b). The butterfly or idling needle must be altered as necessary for the automatic cut-off throttle to function properly.
c). Any inlet needle and seat may be used in any carburetor.
d). Filters or fuel pressure regulators may be added to any fuel line.
e). Fuel line cooling units are permitted.*
- 15 *Two-piece driveshafts are permitted and modifications to adapt approved lower unit gear housing to driveshaft housings are permitted.*
- 16 *Lower unit gear housings may be reduced to measurements as shown on the motor specifications sheets.*
- 17 *There are no water pump specifications on Modified gear units.*
- 18 *After-market pistons are permitted for use in all classes. However, they must meet all specifications for the class.*
- 19 *Any fuel pump is legal on any Modified motor.*
- 20 *It is permissible to tack weld repair any multiple piece crankshaft for the purposes of maintaining alignment.*

B MODIFIED OUTBOARD CLASS*Yamato Engine*

<i>Min. cc's to top of plug hole 14 mm /18 mm</i>	<i>18 cc / 18.5 cc</i>
<i>A</i>	<i>5.980 - 6.024</i>
<i>B</i>	<i>2.752 - 2.760</i>
<i>C</i>	<i>3.885 - 3.906</i>
<i>D</i>	<i>1.800 - 1.830</i>
<i>D1</i>	<i>1.840 - 1.875</i>
<i>E</i>	<i>1.415 - 1.460</i>
<i>F</i>	<i>.010 - .020</i>
<i>G</i>	<i>.016 - .040</i>
<i>H</i>	<i>2.335 – 2.365</i>
<i>H1</i>	<i>13 degrees min – 17 degrees max</i>
<i>J</i>	<i>2.402 Maximum Overbore</i>
<i>K</i>	<i>4.204 - 4.221</i>
<i>KN</i>	<i>5.496 - 5.527</i>
<i>L</i>	<i>2.322 - 2.402</i>
<i>M</i>	<i>2.279 - 2.288</i>
<i>Q</i>	<i>No spec</i>
<i>R</i>	<i>80: 2.25 Minimum / 302: 2.205 Minimum</i>
<i>S</i>	<i>80: 1.195 Minimum / 302: 1.195 Minimum</i>
<i>Flywheel Weight</i>	<i>2.86 Lbs. Minimum – 1,297 Grams</i>
<i>Gear Ratio</i>	<i>80: 14:16 / 302: 14:15</i>
<i>Carburetor - One – BV30 Mikuni</i>	<i>Venturi - .968 – 1.000 Throat 1.165 – 1.197</i>
<i>Carburetor Butterfly Thickness</i>	<i>.053 - .062</i>

<i>Reed Block</i>	<i>Two sets (2 leaves x 2)</i>
<i>Reed Thickness [RT]</i>	<i>.010 - .014</i>

B MODIFIED OUTBOARD CLASS
Yamato Engine

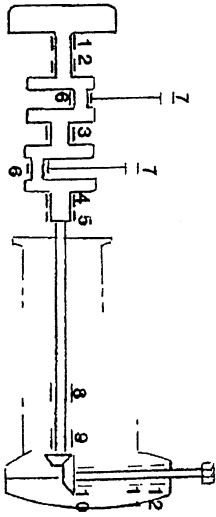

	Name	Size	Number	Name	Size
1	Oil Seal	24 x 40	7	Needle Bearing	15 x 20
2	Needle Bearing	30 x 30	8	Ball Bearing	15 x 35
3	Needle Bearing	28 x 35	9	Needle Bearing	17 x 24
4	Ball Bearing	25 x 52	10	Ball Bearing	15 x 35
5	Oil Seal	25 x 38	11	Needle Bearing	17 x 30
6	Needle Bearing	28 x 35	12	Oil Seal	16 x 30

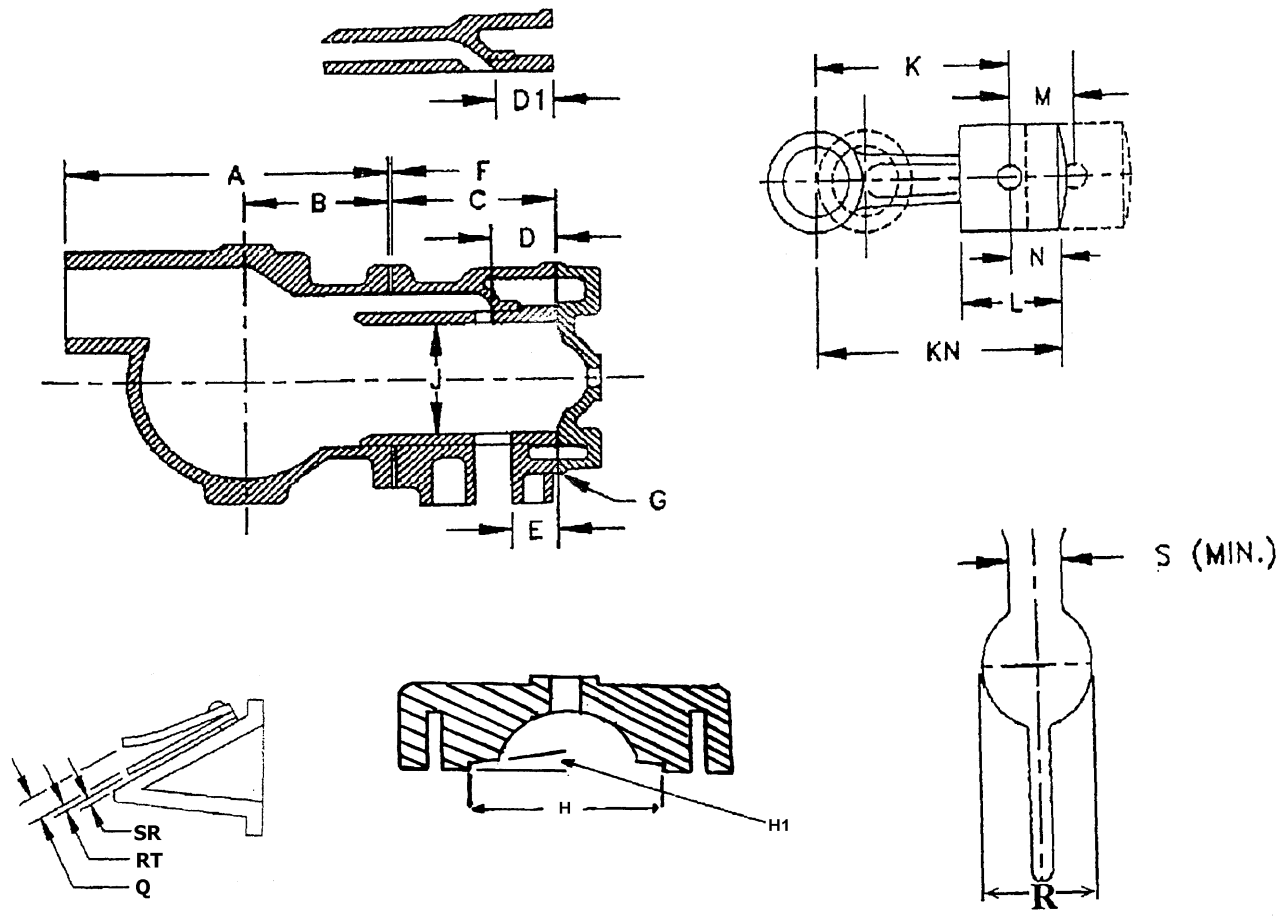

B MODIFIED OUTBOARD CLASS (Formerly 350cc)

BMH, BMR

Engine – OMC 22.1 CI

Mercury - 25SS, 22.0 CI

SPECIFIC TECHNICAL RULES for 22.1 OMC AND 25SS / 22.0 MERCURY

1. *Permitted engines for this class are as follows:*
 - a) *Mercury 25SS*
 - b) *Mercury 22.0 cu. in. Powerhead*
 - 1 – *Use of round top Phelon flywheel is mandatory (Phelon magneto ignition motors)*
 - 2 – *The carb used must not exceed the throat and venturi listed in the tech manual for the 25 Mercury*
 - 3 – *The motor must comply with the specs in the tech manual for the Formula 400 class Mercury*
 - c) *OMC 22.1 cu. in. Powerhead 1970 to date*
 - d) *The motors listed above are legal in BMH and BMR.*
2. *Any lower unit meeting Modified A and Modified B class specifications or the Mercury 25SS specifications is approved for use on any powerhead.*
3. *Thermostats, cowlings, and rewinds may be removed and rope starting plates may be added.*
4. *Piston measurements must be within the tolerances listed.*
5. *Any reed cage supplied by the manufacturer for 22.0 cu. in. Mercury, 1970 or later that lies within the specifications is permitted. Any Mercury brass reed cage which, without modification, meets Formula 400 specifications is permitted. Both the short MK20H-type or longer 25SS type reed cage stops are permitted on any approved cage.*
6. *Reeds of any material are permitted.*
7. *Only carburetors listed in the spec. sheet are permitted.*
8. *Flywheel ring gears, and rewind starter pawl nubs/lugs may be removed from flywheels. Balancing is permitted. On the OMC flywheel it is permitted to remove material and the ring gear. Weights for flywheels are listed on the specification sheet.*
9. *On 25 Mercury engines there are no specifications on exhaust and intake ports. However, no extra ports or passages may be added to the cylinder block. Three intake and three exhaust ports must still be maintained.*
10. *It is permissible to machine OMC cylinder heads. However, the pad must still be showing below the head/cylinder block interface.*

11. Any adjustable high-speed needle and seat is permitted in B Mod carburetors. It is permissible to use any length high speed discharge nozzle in the KC16A Tillotson carburetor.
12. It is permitted to relocate the piston ring retaining pins to other than the OEM location in the piston ring grooves.

Note: Measurements (in chart below) are for standard size piston

Measurement Location	OMC	MERC	Tolerance
Dia. Above top ring	2.4892	2.552	+.003 -.008
Dia. Below 2nd,3rd ring	2.491	2.5565	+.003 -.007
Diameter at skirt	2.496	2.558	+.003 -.006
Taper in Piston	.007	.006	.012 Maximum

13. On OMC Motors only, it is permissible to plug the oil recirculation equipment in the intake, reed plate, crankcase, gasket, and intake deflector cover for the purpose of preventing air leaks.
14. On 25 OMC engines there are no specifications on exhaust and intake ports. However, no extra ports or passages may be added to the cylinder block. Four intake and Four exhaust ports must still be maintained. **(voted 2023)**

PERMISSIBLE MODIFICATIONS AND RESTRICTIONS for B Modified OMC 22.1 / Mercury 25ss / MERCURY 22

THE SPECIFIC DIMENSIONS AND TOLERANCES LISTED BELOW COMBINED WITH THE ABOVE MODIFIED OUTBOARD SPECIFIC CLASS RULES ARE THE ONLY TECHNICAL LIMITATIONS TO BE PLACED ON THE ENGINE BY INSPECTORS.

It is to be clearly understood that all engines, parts, etc. must comply with the dimensions and tolerances shown on the "Official Modified Outboard Specification Sheet". In cases of conflict, the specific class rules shall apply.

- 1 Any type or make of nut, bolt, screw, washer, spark plug, piston ring, propeller, ring pin, fuel line, fuel line fittings, starter plate, spacer plate assembly and ignition parts may be used. **Any bearing, seal, gasket may be used - 2025 Clarification**
- 2 The removal of integral gas tanks, spray shields, protective cowlings, spark plug protectors, compression release valves, fuel filters, starters and their mechanisms and carburetor chokes is permitted.
- 3 Motors may be modernized with the use of parts manufactured for later model motors of the same class. However, if new parts differ from Modified Outboard specification

- sheets, approval of MORC is required. The interchange of parts from one motor to another in these classes is not permitted except where the manufacturer provides interchangeable parts. Crankcase assemblies, for service use or stock racing, with 2.125 stroke, are to be considered interchangeable in the A mod and B Mod classes.
- 4 Open exhaust and special built or tuned exhaust systems are permitted. The addition of material to seal filler blocks and plug water outlets in blocks is permitted. Any new engines approved for use in the Modified category are not allowed to use open megaphone type exhaust systems.
 - 5 Any make or material fabricated motor driveshaft housing and any make or type of clamp and swivel bracket is permitted.
 - 6 The addition of metal to any drive shaft housings and lower unit gear housings is permitted for the specific purposes of strengthening these parts.
 - 7 The addition of material for the specific purpose of installation of cavitation plates to drive shaft housings and spray shields and gas tanks to motors is permitted.
 - 8 It is permitted to rotate the powerhead on the down housing.
 - 9 Any make/material reed cage is permitted in mercury motors provided the following criteria is met:
 - a) Reed number, size, placement and design are the same as stock cage.
 - b) The crankcase does not have to be altered to accept the new cage.
 - c) No extra ports or passages are created in design.
 - d) Lies within specifications which will be shown on the official specification s
 - e) Size of reed port openings shall be measured 3/32 in. below the surface of the reed cage or near the surface if the opening is smaller there.
 - 10 Any Mercury or Quincy production reed block may be used in any Mercury motor as long as it complies with specifications on the Official Modified Outboard Spec Sheet for the class, including the center main bearing surface. It is permitted to fill in oil slots and add material for the specific purpose of increasing the exterior diameter (The intent being to insure a tight fit/seal between the reed block exterior diameter and the crankcase). Any and all surfaces of reed cages may be coated with neoprene or a suitable "plastic" to a maximum thickness of 0.040".
 - 11 It is not permissible to add material (including chrome plate) to cylinder walls.
 - 12 Re-sleeving of cylinders is permitted.
 - 13 Cylinder diameters may be bored, honed or ground to a maximum of 0.050" larger than the manufacturers mean dimension as listed under "G" in the motor specification sheets. Off center or slant boring of cylinders from normal stock center lines and perpendiculars is not permitted.
 - 14 Broken or damaged parts may be repaired by welding or the use of plastic epoxy compounds, provided that all internal dimensions, contours and surfaces or parts are restored as closely as possible to original condition, within specifications. The inspector will pass repairs that meet the word and spirit of this rule and will disqualify engines having repairs which are obviously intended to provide an unfair advantage.

- 15 *Material may be added to or removed from flywheels for balance purposes. Service engine flywheels may be machined down to racing size and weights, provided the weight of such flywheel is not reduced to less than the minimum specified for that class engine. Flywheels must not be interchanged between classes unless specifically intended by the original engine manufacturer.*
- 16 *Removal of material from non-reciprocating parts (pistons and rod assemblies are classified as reciprocating) is permitted except as noted in these rules and specification sheets.*
- 17 *Removal of material from reciprocating parts, except for balancing and polishing is prohibited except where permitted in these rules and specification sheets.*
- 18 *The polishing of moving parts and passages is permitted except where prohibited by individual class rules and specification sheets.*
- 19 *Beveling of crankshafts is permitted except where removal of material is prohibited by individual class rules and specification sheets.*
- 20 *No extra ports or passageways are allowed in the powerhead except where permitted in individual class rules and specification sheets.*
- 21 *Enlarging of intake and exhaust ports is permitted except where prohibited by individual class rules and specification sheets.*
- 22 *Removal of material by drilling holes, etc., into combustion chambers for the purpose of introducing water in that area is prohibited.*
- 23 *The addition of material for any purpose is prohibited except as noted:*
 - a) *Elsewhere in these modified rules specifically.*
 - b) *Addition of material to the outside of piston skirts is approved, specifically meaning “coating” of skirts OD with a material to increase diameter, except the 25xs motor running in BMR.*
 - c) *Primers may be added, and gas fittings installed in any carburetor or reed cage area. It is not permitted to use this as an accelerator pump or power jet.*
 - d) *Addition of thermal barrier coatings to piston crowns is approved. However, crown dimensions must remain as manufactured.*
- 24 *Alterations to carburetor and fuel systems are permitted as follows:*
 - a) *For marathon use, an auxiliary fuel supply connection may be added to the carburetor.*
 - b) *The butterfly or idling needle must be altered as necessary for the automatic cut-off throttle to function properly.*
 - c) *Adapters or extra length high-speed needles are permitted.*
 - d) *Any inlet needle and seat may be used in any carburetor.*
 - e) *Material may be added to stiffen float levers in Carter model N carburetors.*
 - f) *Filters or fuel pressure regulators may be added to any fuel line.*
 - g) *All KA model Tillotson carburetors having a one-inch venturi are legal for use on all class A, B Modified engines provided they measure within KA7A model specifications and the use of adjustable high-speed needles and seats from KA7A carburetors and conversion kit no. 2619A1 is permitted.*
 - h) *Fuel line cooling units are permitted.*

- 25 *Two-piece driveshafts are permitted and modifications to adapt approved lower unit gear housing to driveshaft housings are permitted.*
- 26 *Lower unit gear housings may be reduced to measurements as shown on the motor specifications sheets. The addition or removal of material on gear cases is permitted as long as “R” and “S” dimensions are maintained.*
- 27 *There are no water pump specifications on Modified gear units.*
- 28 *After-market pistons are permitted for use in all classes. However, they must meet all specifications for the class.*
- 29 *Any fuel pump is legal on any modified motor.*

B MODIFIED OUTBOARD CLASS

OMC 22.1 CI

Mercury - 25SS, 22.0 CI

CLASS	25 MOD motor in B Modified	25 MOD motor in B Modified
ENGINE	OMC	MERCURY
<i>Min cc's to top of plug hole</i>	19.0	22.0
A		
A1		
C		
C1		
G	2.450 – 2.550	2.516 – 2.616
J	2.242 – 2.258	2.119 – 2.131
K	5.940 – 6.010	
M	.5950 Minimum	
N	1.600 Minimum	
<i>Min. Flywheel weight With Rope Plate</i> ***	3 Lb. 13 oz. – 2 magnet flywheel 2 Lb. 8 oz. – 1 magnet flywheel 4 Lb. Min. – OMC CD flywheel	5 Lb. 4 oz.
Y		Brass 1.00 +/- 1/32 Brass 1.21875 +/- 1/32 AL 1.21874 +/- 1/32 AL 1.3125 +/- 1/32
R / S Min	Mercury 2.0 / .875 Hot Rod 2.063 / .750	Mercury 2.0 / .875 Hot Rod 2.063 / .750
<i>Number & thickness of rings</i>	One .0625, .088 or 2 -.0625	Two or three .062 - .057
<i>Number of holes per cylinder in Reed Cage</i>	8 @ .531 - .563	4
Carburetors	One – OMC 25 Venturi 1.031 – 1.156 Throat 1.375 – 1.516	One Tillotson KA Venturi .984 – 1.016 Throat 1.109 – 1.141 OR One Tillotson KC16A Venturi 1.0465 – 1.0785 Throat 1.234 – 1.266*****
<i>Number of intake ports per cylinder.</i>	4	3
<i>Number of exhaust ports per cylinder.</i>	4	3
<i>Reed cage surface</i>		Aluminum or Brass

***** OMC CD flywheel is of an eggshell design. It must be used as received from manufacturer.

***** KC16A Throat Measurement to be measured at point where butterfly contacts throat wall.

B MODIFIED OUTBOARD CLASS

OMC 22.1 CI

Mercury - 25SS, 22.0 CI

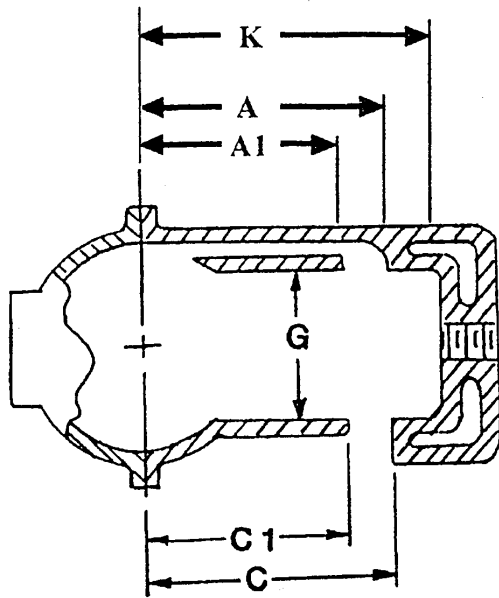

OMC Flywheel

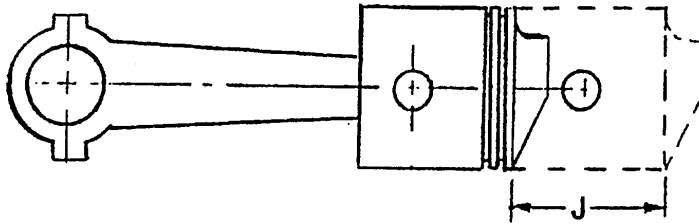
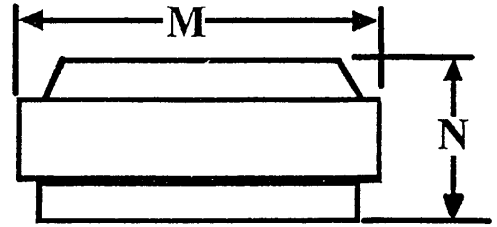

**Mercury
Reed Cage**

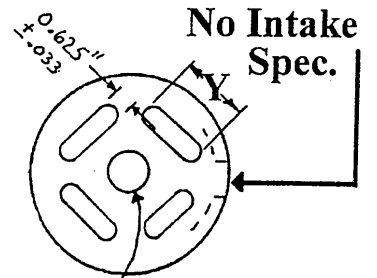

**I.D. Any Oil
Grooves**

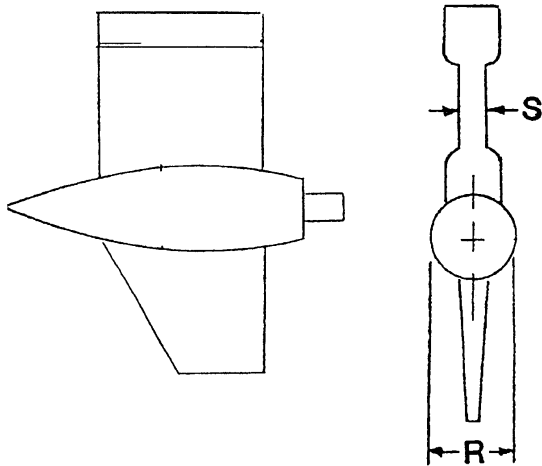

Y

Brass 1.00"
OR 1.21875"
Alum. 1.21875"
OR 1.3125"
+/- .033"

B MODIFIED OUTBOARD CLASS (Formerly 350cc)

BMH, BMR

Engine – **Hot Rod**
Mercury 20.0 cu in

SPECIFIC TECHNICAL RULES for B Modified HOT ROD / MERCURY MODIFIED OUTBOARD

1. *Main bearing bores in crankcases may be bored and fitted with bushings to provide a good fit on standard crankshaft main bearings. Alternatively, the crankcase may be bored to accept ball bearings, having oversize outside diameters but which are otherwise standard.*
2. *Any ignition may be used on the listed B Modified class engine.*
3. *Phelon service flywheels of cast construction (square top) such as Mark 25 Merc and Sweet 16 Champion shall not be used.*
4. *In no case shall the small taper bore flywheel (Hot Rod, KG4, etc.) Be machined out to fit on the larger taper crankshafts (MK20H, etc.).*
5. *Any approved two-cylinder carburetor may be used on any engine.*
6. *Float systems may be removed from Carter Model N carburetors and a return line installed.*
 - a) *Carter model N carburetors are approved for use on B Modified class motors.*
 - b) *Material may be added to stiffen the float levers in Carter model N carburetors.*
 - c) *All KA model Tillotson carburetors having a 1" venturi and 1-1/8" throat are permitted for use on B Modified class engine.*
6. *The Formula 400 Hot Rod and 20 C.I. Mercury engines are permitted in the B Modified Runabout and B Modified Hydro provided it meets all Formula 400 rules.*
8. *Any make deflector piston is permitted in the B Modified class Hot Rod engines provided the measurements of the pistons comply with the motor specifications. The specified number and width of the ring grooves and the location of the top groove must be the same as on the factory replacement pistons.*
9. *Mercury fuel pumps and Tillotson KA carburetors are permitted for use on Hot Rod B Modified class engines. When necessary, adapters may be added to the crankcase front to provide the required intake diameter and stud pattern.*
10. *Due to the fact that the outer skin of the casting significantly contributes to the strength of the OMC aluminum flywheels furnished on A Modified or B Modified class Hot Rods, it shall not be permissible to alter them from the original supplied configuration.*

11. *B Modified class Mercury engines shall have the following specifications. Motors may be modified by removal or addition of material in any manner except for the following:*
 - a) *Engine must remain a deflector crossflow design*
 - b) *No extra ports or passages are permitted in the piston or cylinder block except to allow for piston porting the crankcase induction cycle.*
 - c) *No superchargers or turbochargers are permitted.*
 - d) *You must continue to use the Mercury 15 cu. in., 20 cu. in. motor block and crankshaft (stroke may not be altered). The 22-cu. in. Mercury crankshaft may be used in the Mark 20 Mercury motors.*
 - e) *Any Mercury or Quincy with the same bolt pattern (as cast) crankcase is permitted and are interchangeable.*
 - f) *Pistons must be of deflector type. Any number, type or thickness of piston rings may be used.*
 - g) *Metal may be added to or removed from flywheels for balance purposes. Service engine flywheels may be machined down to racing size and weight, provided the weight of such flywheel is not reduced to less than the minimum specified for that class engine on which it was originally used. Flywheels must not be interchanged between classes unless specifically intended by the original engine manufacturer.*
 - h) *There are no specifications on the reed cage. No reed stop heights apply.*
 - i) *Any Mercury or Hot Rod lower unit gear housing is approved. However, R/S dimensions must be maintained.*
12. *Only the Hot Rod and Sidewinder 15 / 20 lower unit gear housing may be adapted to B Modified class Hot Rod power heads.*
13. *Material may be added to the exterior of A, B, C and Formula 400 Modified class Mercury lower unit gear housings to duplicate the contours of the Mercury 25XS housing.*
14. *Material may be added to exterior of the Hot Rod cylinder block and crankcase for the purpose of re-enforcement. All machined surfaces, internal surfaces, contours, and dimensions must remain as close as possible to their original condition. Inspectors may rule out modifications that do not meet the spirit of this rule.*
15. *It is permissible to thermal barrier coat the piston crowns provided the overall piston and crown dimensions are not changed.*

16. Any fuel pump is legal.
17. For Hot Rod engines, it is permissible to add material to alter the cooling water flow or direction.
18. The Full Circle Hot Rod Field / Moulder replacement crankshaft produced by Nathaniel Field and Thomas Moulder is legal in the B Mod classes.

PERMISSIBLE MODIFICATIONS AND RESTRICTIONS for B Modified HOT ROD / MERCURY MODIFIED OUTBOARD

THE SPECIFIC DIMENSIONS AND TOLERANCES LISTED BELOW COMBINED WITH THE ABOVE MODIFIED OUTBOARD SPECIFIC CLASS RULES ARE THE ONLY TECHNICAL LIMITATIONS TO BE PLACED ON THE ENGINE BY INSPECTORS.

It is to be clearly understood that all engines, parts, etc. must comply with the dimensions and tolerances shown on the "Official Modified Outboard Specification Sheet". In cases of conflict, the specific class rules shall apply.

- 1 Any type or make of nut, bolt, screw, washer, spark plug, piston ring, propeller, ring pin, fuel line, fuel line fittings, starter plate, spacer plate assembly and ignition parts may be used **Any bearing, seal, gasket may be used - 2025 Clarification**
- 2 The removal of integral gas tanks, spray shields, protective cowlings, spark plug protectors, compression release valves, fuel filters, starters and their mechanisms and carburetor chokes are permitted.
- 3 Motors may be modernized with the use of parts manufactured for later model motors of the same class. However, if new parts differ from Modified Outboard specification sheets, approval of MORC is required. The interchange of parts from one motor to another in these classes is not permitted except where the manufacturer provides interchangeable parts. Crankcase assemblies, for service use or stock racing, with 2.125 stroke, are to be considered interchangeable in the A and B Modified classes.
- 4 Open exhaust and special built or tuned exhaust systems are permitted. The addition of material to seal filler blocks and plug water outlets in blocks is permitted. Any new engines approved for use in the Modified category are not allowed to use open megaphone type exhaust systems.
- 5 Any make or material fabricated motor driveshaft housing and any make or type of clamp and swivel bracket is permitted.
- 6 The addition of metal to any drive shaft housings and lower unit gear housings is permitted for the specific purposes of strengthening these parts.
- 7 The addition of material for the specific purpose of installation of cavitation plates to drive shaft housings and spray shields and gas tanks to motors is permitted.
- 8 It is permitted to rotate the powerhead on the down housing.

- 9 *Any make/material reed cage is permitted in mercury motors provided the following criteria is met:
 - a) *Reed number, size, placement and design are the same as stock cage.*
 - b) *The crankcase does not have to be altered to accept the new cage.*
 - c) *No extra ports or passages are created in design.*
 - d) *Lies within specifications which will be shown on the official specification s*
 - e) *Size of reed port openings shall be measured 3/32 in. below the surface of the reed cage or near the surface if the opening is smaller there.**
- 10 *Any Mercury or Quincy production reed block may be used in any Mercury motor as long as it complies with specifications on the Official Modified Outboard Spec Sheet for the class, including the center main bearing surface. It is permitted to fill in oil slots and add material for the specific purpose of increasing the exterior diameter (The intent being to insure a tight fit/seal between the reed block exterior diameter and the crankcase). All surfaces of reed cages may be coated with neoprene or a suitable "plastic" to a maximum thickness of 0.040.*
- 11 *It is not permissible to add material (including chrome plate) to cylinder walls.*
- 12 *Re-sleeving of cylinders is permitted.*
- 13 *Cylinder diameters may be bored, honed or ground to a maximum of 0.050" larger than the manufacturers mean dimension as listed under "G" in the motor specification sheets. Off center or slant boring of cylinders from normal stock center lines and perpendiculars is not permitted.*
- 14 *Broken or damaged parts may be repaired by welding or the use of plastic epoxy compounds, provided that all internal dimensions, contours and surfaces or parts are restored as closely as possible to original condition, within specifications. The inspector will pass repairs that meet the word and spirit of this rule and will disqualify engines having repairs which are obviously intended to provide an unfair advantage.*
- 15 *Material may be added to or removed from flywheels for balance purposes. Service engine flywheels may be machined down to racing size and weights, provided the weight of such flywheel is not reduced to less than the minimum specified for that class engine. Flywheel must not be interchanged between classes unless specifically intended by the original engine manufacturer.*
- 16 *Removal of material from non-reciprocating parts (pistons and rod assemblies are classified as reciprocating) is permitted except as noted in these rules and specification sheets.*
- 17 *Removal of material from reciprocating parts, except for balancing and polishing is prohibited except where permitted in these rules and specification sheets.*
- 18 *The polishing of moving parts and passages is permitted except where prohibited by individual class rules and specification sheets.*
- 19 *Beveling of crankshafts is permitted except where removal of material is prohibited by individual class rules and specification sheets.*

- 20 *No extra ports or passageways are allowed in the powerhead except where permitted in individual class rules and specification sheets.*
- 21 *Enlarging of intake and exhaust ports is permitted except where prohibited by individual class rules and specification sheets.*
- 22 *Removal of material by drilling holes, etc., into combustion chambers for the purpose of introducing water in that area is prohibited.*
- 23 *Indexing of pistons is permitted with the tolerances as specified in the “E” and “EE” measurement for that specific engine.*
- 24 *The addition of material for any purpose is prohibited except as noted:*
a) Elsewhere in these modified rules specifically.
b) Addition of material to the outside of piston skirts is approved, specifically meaning “coating” of skirts OD with a material to increase diameter, except the 25xs motor running in BMR.
c) Primers may be added, and gas fittings installed in any carburetor or reed cage area. It is not permitted to use this as an accelerator pump or power jet.
d). Addition of thermal barrier coatings to piston crowns is approved. However, crown dimensions must remain as manufactured.
- 25 *Alterations to carburetor and fuel systems are permitted as follows:*
a). For marathon use, an auxiliary fuel supply connection may be added to the carburetor.
b). The butterfly or idling needle must be altered as necessary in order for the automatic cut-off throttle to function properly.
c). Adapters or extra length high-speed needles are permitted.
d). Any inlet needle and seat may be used in any carburetor.
e). Material may be added to stiffen float levers in Carter model N carburetors.
f). Filters or fuel pressure regulators may be added to any fuel line.
g). All KA model Tillotson carburetors having a one inch venturi are legal for use on all class A, B, C and D Modified engines provided they measure within KA7A model specifications and the use of adjustable high speed needles and seats from KA7A carburetors and conversion kit no. 2619A1 is permitted.
h). Fuel line cooling units are permitted.
- 26 *Two-piece driveshafts are permitted and modifications to adapt approved lower unit gear housing to driveshaft housings are permitted.*
- 27 *Lower unit gear housings may be reduced to measurements as shown on the motor specifications sheets. The addition or removal of material on gear cases is permitted as long as “R” and “S” dimensions are maintained.*
- 28 *There are no water pump specifications on Modified gear units.*
- 29 *After-market pistons are permitted for use in all classes. However, they must meet all specifications for the class.*
- 30 *Any fuel pump is legal on any Modified motor.*

B MODIFIED OUTBOARD CLASS
Hot Rod and Mercury

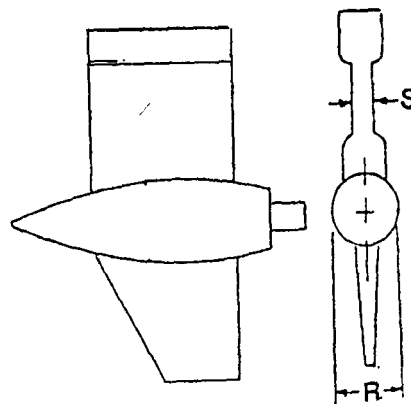
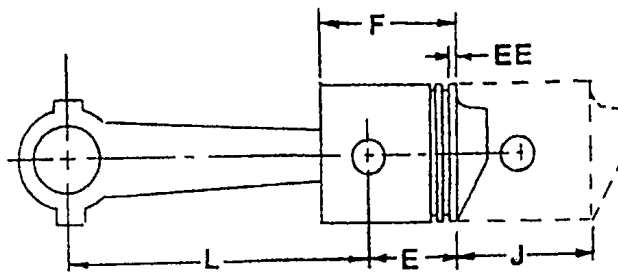
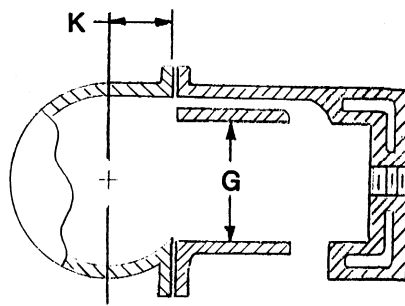

B MODIFIED OUTBOARD CLASS
Hot Rod and Mercury

CLASS	B MOD	B MOD
ENGINE	HOT ROD	MERCURY
<i>Minimum CC's to top of plug Hole</i>	17.0	
<i>EE</i>	.125 - .250	
<i>E</i>	1.125 - 1.250	
<i>F</i>	2.00 - 2.125	
<i>G</i>	2.450 - 2.550	2.390 - 2.490
<i>J (STROKE)</i>	1.999 - 2.046	2.105 - 2.145
<i>K</i>	1.812 - 1.874	
<i>L</i>	3.547 - 3.577	
<i>R/S Minimum</i>	2.063 / .750	2.0 / .875
<i>Piston weight w/rings pin & fastener</i>	6 oz.	
<i>Number & Thickness of Rings</i>	Two - .062 or Two - .046	
<i>Rod Weights w/ Bearings Screws & Spacers</i>	5 oz.	
<i>Rotary Valve Opens</i>	1.844 - 1.968 from TDC	
<i>Rotary Valve Closes</i>	.562 - .812 from TDC	
<i>Carburetors</i>	See List on Following page	One
<i>Number of Intake Ports per cylinder</i>		3
<i>Number of exhaust Ports per cylinder</i>		3
<i>Gear Ratio</i>	14:15 or 14:19	1:1,16:21,14:15, or 14:19

B MODIFIED HOT ROD CARBURETOR CHART

CARBURETOR	VENTURI +/- .016 unless otherwise specified	THROAT +/- .016 unless otherwise specified
<i>Tillotson HL & CR1A</i>	<i>7/8"</i>	<i>1"</i>
<i>Tillotson AJ49 & 51</i>	<i>13/16"</i>	<i>61/64" x 1-3/32"</i>
<i>Tillotson KA</i>	<i>1"</i>	<i>1-1/8"</i>
<i>Tillotson HR</i>	<i>1-9/32"</i>	<i>1-3/8"</i>
<i>Carter Model N</i>	<i>15/16"</i>	<i>1-5/16"</i>
<i>WR6</i>	<i>1-9/32 +/- 1/16"</i>	<i>1-3/8 +/- 1/16"</i>
<i>WRC1</i>	<i>1" +/- 1/16"</i>	<i>1-5/16" +/- 1/16"</i>
<i>Lectron 30, 32, 34</i>	<i>N/A</i>	<i>30 mm, 32 mm, 34 mm</i>

B MODIFIED OUTBOARD CLASS (Formerly 350cc)

BMR (only)

Engine – Mercury / Mariner 25XS

SPECIFIC TECHNICAL RULES for BMR 25XS MERCURY MODIFIED OUTBOARD

Note: It is the intention of the manufacturer and the MORC that the 25XS engine be raced as received from the manufacturer without modification.

1. No modifications of any kind including grinding, polishing, machining, shot peening, bead blasting, etc. will be allowed on any engine or drive components unless otherwise noted in this section. No material may be added or removed from any engine or drive component unless otherwise noted in this section.
2. The engine must retain its complete original factory color, decals and cowlings. The paint may be removed from the external cast surfaces of the cylinder block.
3. Only cylinder blocks, pistons and piston rings manufactured by Mercury Marine are allowed.
4. The original 25XS cylinder blocks are aluminum with chrome bores. Late model cylinder blocks with Mercosil (aluminum) bores are legal replacement parts for the cylinder blocks with chrome bores. No other configurations will be allowed. The Mercury part numbers for the Mercosil cylinder block and related components are: cylinder block P/N 872-9533T29, P/N 872-9533T38, and P/N 872-9533T39; Piston: P/N 767-879878T5, P/N 767-821968A3, 767-855283T2, and 767-855283T3; and Piston Rings 39-827491A12. The part numbers of the cylinder blocks with chrome bores and related components are: cylinder block P/N 872-9533A2, and P/N 872-9533A3, Pistons P/N 767-9104A10, P/N 767-9104A11, P/N 767-9104A17, P/N 767-9104A18, P/N 767-9104A19, and P/N 767-9104T19.
5. The minimum allowable volume of the combustion chamber, at T.D.C., to the top of the spark plug hole for engines with chrome bores is 21.7 CM. The minimum allowable volume of the combustion chamber, at T.D.C., to the top of the spark plug hole for engines with Mercosil aluminum bores is 21.2 CM.
6. Phillips head fasteners may be replaced with hex head screws. Larger diameter starter mounting screws and/or studs, washers and nuts with rubber isolation washers are permissible. Throttle butterfly screws, connecting rod fasteners and nuts must be factory original. Gearcase mounting studs must be factory original but may be altered to allow increased clearance.
7. Any make of seals, bearings, fuel line, throttle bracket, or thrust bracket, may be used provided other parts are not altered to accommodate them.
8. It is not permissible to machine off the mating surfaces of the split crankcase.
9. The main bearing bores in the crankcase may not be bored to accept oversize bearings or fitted with bushings.
10. Material may be added to the recoil housing. Internal flywheel to housing clearance must not be changed.
11. Honing of the cylinder bores and connecting rod journal bores is permitted.
12. The 25XD carburetor is legal for the 25XS engine if it is fitted with a full butterfly. The model numbers for carburetors having the same venturi and throat diameters as the 25XS carburetor (Walbro WX-2263) are WMC-1, WMC-3, WMC-11 WMC-13, and 1390-8889A20.
13. All 25XS engines must be run with the carburetor restrictor plate (P/N 19706) as shown in drawing herein. This restrictor plate will be manufactured solely by Mercury Marine with an "HPP" stamp on it and may not be modified in any way.

14. It is permissible to add a second pair of cross-drilled holes, at 90° to the original fuel inlet holes in the high-speed jet holder. They must be the same diameter (0.096 inches) as the original holes. It is NOT permissible to add an adjustable needle valve to any of the legal carburetors.
15. Approved reed cage assemblies are P/N 42471-2 (casting no. 41380-C1) and P/N 14112.
16. The following reeds are approved for the 25XS engine: Steel reed (Mercury P/N 34-99319 & P/N 34-816806). Plastic reed (Mercury P/N 34-814764A1 & P/N 34-848066), reed cage P/N 14112.
17. It is permissible to use replacement reeds manufactured by Boyesen.
18. There are two (2) legal flywheels for the 25XS engine. P/N 258-8274A6 (9 lb. 7 oz. Min. weight) and P/N 258-8274A11 (7 lb. 8 oz. min. weight) are both legal flywheels.
19. There are two legal driveshaft housings for the 25XS engine: The "long" housing manufactured before 1986, and the "short" housing manufactured after 1986.
20. The only legal gearcase for the 25XS engine is the larger skeg gearcase (P/N 1604-1116A15). The gearcase may be unpainted or must be completely painted in original factory colors (tail cone need not be painted). This gearcase must meet the specifications on the attached page and on the Mercury template (#91-17456). Note: This inspection template must be checked for dimensional accuracy before each use.
21. The clamp bracket screw handles may be repaired or replaced with an alternative handle as long as no modifications are required on the bracket of the driveshaft housing.
22. The steering arms that come standard on the "short" 25XS driveshaft housing may be replaced with new arms if they have at least the same minimum cross section dimensions (1.0-inch horizontal X 0.25 inch vertical). Material may be either steel or aluminum.
23. The lower tower housing swivel pin bushing may be replaced with any type of bushing provided no modifications are made to the tower housing, pin or clamp bracket assembly.
24. It is permissible to remove the plastic baffle in the top of the upper engine cowling on all models.
25. It is permissible to use replacement ignition parts manufactured by Rapair.
26. It is permissible to use an electric starter, as provided by the motor manufacturer and is limited to a 12-volt DC system.
27. Any fuel pump is legal.
28. Engine height is 1" below bottom of the boat at center of prop shaft.

MERCURY / MARINER 25XS RESTRICTOR SPECIFICATIONS FOR BMR

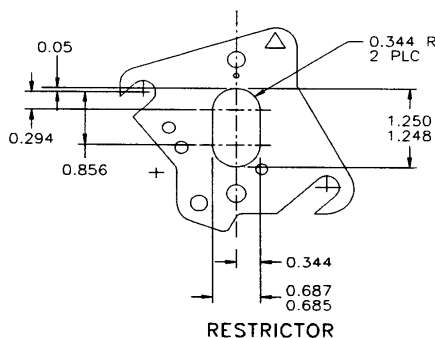

MERCURY / MARINER 25XS SPECIFICATIONS FOR BMR

ENGINE MODEL		MERCURY	25XS
		MARINER	
VOLUME OF COMBUSTION CHAMBER AT T. D. C. TO TOP OF SPARK PLUG HOLE		MIN. CM ³	21.7
NUMBER OF CYLINDERS			2
DISPLACEMENT (CUBIC INCH)			24.4
CENTER OF CRANK PIN TO TOP OF PISTON		E	5.277 ±0.020
PISTON HEIGHT		F	2.525 ±0.030
CYLINDER BORE DIAMETER		G	2.563 ±0.003 (REF.) 2.566 MAX
CRANK STROKE		J	2.362 ±0.005
ROD LENGTH		L	4.062 ±0.005
PISTON WEIGHT (INCL. RINGS, PIN, & CLIPS)			260 GRAMS MIN.
PISTON	NUMBER PER PISTON		2
	MATERIAL		CAST IRON
	THICKNESS	UPPER	0.060 ±0.002
		LOWER	0.060 ±0.002
RINGS	DESIGN	UPPER	HALF KEYSTONE
	LOWER		RECTANGULAR
NO. OF PORTS PER CYLINDER	TRANSFER		3
	EXHAUST		1
PORT HEIGHT	TRANSFER	A	4.493 ±0.030
	EXHAUST	C	4.863 ±0.030
PORT DIMENSION	TRANSFER	A1	0.395 ±0.030
		A2	0.450 ±0.030
		A3	1.079 ±0.030
		A4	0.957 ±0.030
		A5	1.114 ±0.030
	EXHAUST	C1	0.750 ±0.030
		C2	1.488 ±0.030
		K	6.528 ±0.010
CYLINDER BLOCK HEIGHT	LENGTH	M	0.700 ±0.030
	WIDTH (NOT SHOWN)	N	0.550 ±0.020
REED BLOCL OPENINGS 6 OPENINGS PER CYL.	STOP HEIGHT		0.260 ±0.030 (P/N 42471-2)
			0.285 ±0.020 (P/N 14112)
	TIP TO SCREW CL	Y	1.260 ±0.020 (P/N 42471-2)
	THICKNESS - STEEL		1.165 ±0.020 (P/N 14112)
			D
THICKNESS - FIBER		D	0.020 ±0.002
FLYWHEEL WEIGHT (HEAVY)			9 LBS. 7 OZ. MIN.
FLYWHEEL WEIGHT (LIGHT)			7 LBS. 8 OZ. MIN.
CARBURETOR	VENTURI DIAMETER		1.12 ±0.015
	THROAT DIAMETER		1.25 ±0.015
EXHAUST SPECIFICATIONS	EXHAUST PIPE LENGTH (TOP OF ADAPTOR TO BOTTOM OF PIPE)	D	7.120 ±0.150
	HOUSING (MEASURED W/ EXHAUST ADAPTOR)	V	14.625 ±0.060 (LONG)
	HOUSING	V	9.750 ±0.060 (SHORT)
EXHAUST OUTLET DIMENSION			2.00 X 2.00 (+0.25)
GEARCASE SPECIFICATIONS	GEAR RATIO		16:21 OR 15:15
	Q		11.25 MAX.
	R		2.09 MIN.
	S		0.95 MIN.
	W		1.870 MIN.

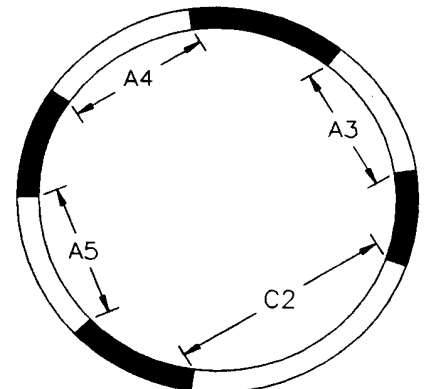
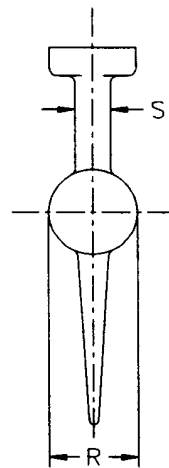
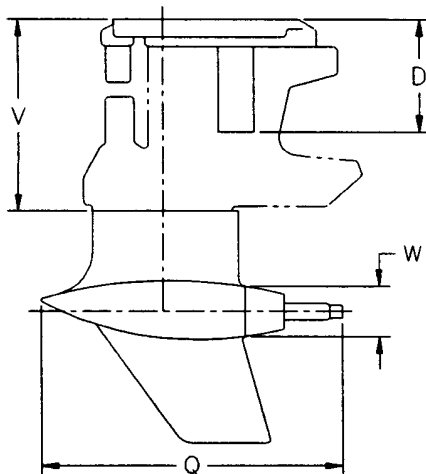
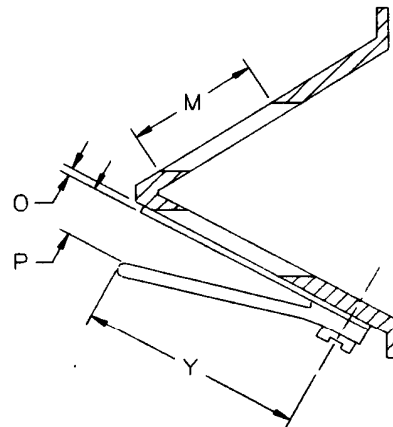
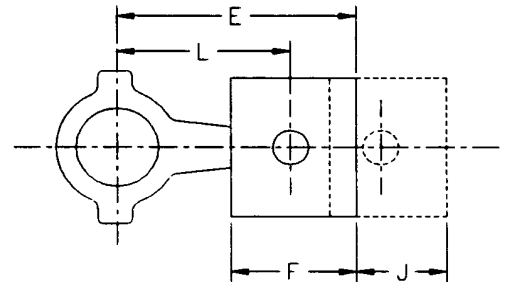
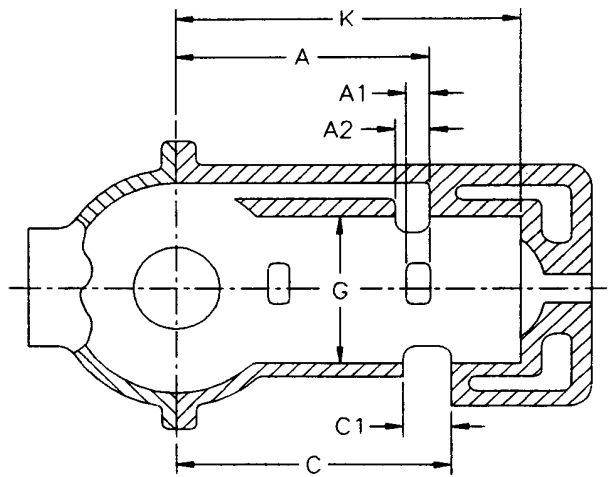

Formula 400 MODIFIED HYDRO (Formerly 400cc Hydro)

Engine - OMC 22 CI
Mercury 22 CI
Hot Rod 20 CI – (use B Modified Hot Rod engine rules)
Mercury 20 CI – (use B Modified Mercury engine rules)

SPECIFIC TECHNICAL RULES for Formula 400 MODIFIED HYDRO

1. Permitted engines for this class are as follows:
 - a) Mercury 25SS
 - b) Mercury 22.0 cu. in. Powerhead
 1. – Use of round top Phelon flywheel is mandatory (Phelon magneto ignition motors)
 2. – The carb used must not exceed the throat and venturi listed in the tech manual for the 25 Mercury
 3. – The motor must comply with the specs in the tech manual for the 25 Mercury
 - c) OMC 22.1 cu. in. Powerhead 1970 to date
 - d) 20 cu in Mercury as defined in A Mod & B Mod specs
 - e) The motors listed above are also legal in BMH and BMR.
 - f) The 20-cu. in. Hot Rod rotor valve motor. Use specifications and rules listed for this motor in the B Mod Class.
2. Any lower unit meeting Modified A and B / C Yamato specifications or the Mercury 25SS specifications is approved for use on any powerhead.
3. Thermostats, cowlings, and rewinds may be removed and rope starting plates may be added.
4. Piston measurements must be within the tolerances listed.
5. Reeds of any material are permitted.
6. Only carburetors listed in the spec. sheet are permitted.
7. Any ignition system is permitted on the OMC and Mercury powerheads. In the event an OEM flywheel ignition system is used, ring gears and rewind starter pawl nubs/lugs may be removed from the flywheels. Balancing is permitted. On the OMC flywheel, it is permitted to remove material and the ring gear. Mandatory minimum weights for OEM flywheels are listed on the class specification sheet. The use of the center hub of OEM flywheels or machined versions thereof to accommodate the use of aftermarket ignition systems is permitted.
8. On Formula 400 Mod Mercury there are no specifications on exhaust and intake ports. However, no extra ports or passages may be added to the cylinder block. Three intake and three exhaust ports must still be maintained.
9. It is permissible to machine OMC cylinder heads. However, the pad must still be showing below the head/cylinder block interface.

10. Any adjustable high-speed needle and seat is permitted in Formula 400 Mod carburetors. It is permissible to use any length high speed discharge nozzle in the KC16A Tillotson carburetor.
11. It is permitted to relocate the piston ring retaining pins to other than the OEM location in the piston ring grooves.
12. On OMC motors only, it is permissible to plug the oil recirculation equipment in the intake, reed plate, crankcase, gasket, and intake deflector cover for the purpose of preventing air leaks.
13. Re-sleeving of cylinders is permitted in Formula 400 Mod engines.
14. On the Mercury 25SS and the Mercury 22 cu. In. powerheads, it is permissible to use newer intake port covers.
15. It is permitted to add a velocity stack (forced venture) to the carburetors used on Formula 400 Mod motors.
16. The Full Circle Hot Rod Field/Moulder replacement crankshaft produced by Nathaniel Field and Thomas Moulder is legal in the Formula 400 Mod Hydro class.
17. On 22 OMC there are no specifications on exhaust and intake ports. However, no extra ports or passages may be added to the cylinder block. Four intake and four exhaust ports must still be maintained. (Per class vote 2023)

PERMISSIBLE MODIFICATIONS AND RESTRICTIONS for the Formula 400 MODIFIED HYDRO
 THE SPECIFIC DIMENSIONS AND TOLERANCES LISTED BELOW COMBINED WITH THE ABOVE MODIFIED OUTBOARD SPECIFIC CLASS RULES ARE THE ONLY TECHNICAL LIMITATIONS TO BE PLACED ON THE ENGINE BY INSPECTORS.

It is to be clearly understood that all engines, parts, etc. must comply with the dimensions and tolerances shown on the "Official Modified Outboard Specification Sheet". In cases of conflict, the specific class rules shall apply.

1. Any type or make of nut, bolt, screw, washer, spark plug, piston ring, propeller, ring pin, fuel line, fuel line fittings, starter plate, spacer plate assembly and ignition parts may be used. **Any bearing, seal, gasket may be used - 2025 Clarification**
2. The removal of integral gas tanks, spray shields, protective cowlings, spark plug protectors, compression release valves, fuel filters, starters and their mechanisms and carburetor chokes are permitted.
3. Motors may be modernized with the use of parts manufactured for later model motors of the same class. However, if new parts differ from Modified Outboard specification sheets, approval of MORC is required. The interchange of parts from one motor to another in these classes is not permitted except where the manufacturer provides interchangeable parts. Crankcase assemblies, for service use or stock racing, with 2.125 stroke, are to be considered interchangeable in the A and B Modified classes.

- 4 *Open exhaust and special built or tuned exhaust systems are permitted. The addition of material to seal filler blocks and plug water outlets in blocks is permitted. Any new engines approved for use in the Modified category are not allowed to use open megaphone type exhaust systems.*
- 5 *Any make or material fabricated motor driveshaft housing and any make or type of clamp and swivel bracket is permitted.*
- 6 *The addition of metal to any drive shaft housings and lower unit gear housings is permitted for the specific purposes of strengthening these parts.*
- 7 *The addition of material for the specific purpose of installation of cavitation plates to drive shaft housings and spray shields and gas tanks to motors is permitted.*
- 8 *It is permitted to rotate the powerhead on the down housing.*
- 9 *Any make/material reed cage is permitted in mercury motors provided the following criteria is met:*
 - a) *Reed number, size, placement and design are the same as stock cage.*
 - b) *The crankcase does not have to be altered to accept the new cage.*
 - c) *No extra ports or passages are created in design.*
 - d) *Lies within specifications which will be shown on the official specification s*
 - e) *Size of reed port openings shall be measured 3/32 in. below the surface of the reed cage or near the surface if the opening is smaller there.*
- 10 *Cylinder diameters may be bored, honed or ground to a maximum of 0.050" larger than the manufacturers mean dimension as listed under "G" in the motor specification sheets. Off center or slant boring of cylinders from normal stock center lines and perpendiculars is not permitted.*
- 11 *Broken or damaged parts may be repaired by welding or the use of plastic epoxy compounds, provided that all internal dimensions, contours and surfaces or parts are restored as closely as possible to original condition, within specifications. The inspector will pass repairs that meet the word and spirit of this rule and will disqualify engines having repairs which are obviously intended to provide an unfair advantage.*
- 12 *Removal of material from non-reciprocating parts (pistons and rod assemblies are classified as reciprocating) is permitted except as noted in these rules and specification sheets.*
- 13 *Removal of material from reciprocating parts, except for balancing and polishing is prohibited except where permitted in these rules and specification sheets.*
- 14 *The polishing of moving parts and passages is permitted except where prohibited by individual class rules and specification sheets.*
- 15 *Beveling of crankshafts is permitted except where removal of material is prohibited by individual class rules and specification sheets.*
- 16 *Removal of material by drilling holes, etc., into combustion chambers for the purpose of introducing water in that area is prohibited.*

- 17 *The addition of material for any purpose is prohibited except as noted:*
- a) *Elsewhere in these modified rules specifically.*
 - b) *Addition of material to the outside of piston skirts is approved, specifically meaning “coating” of skirts OD with a material to increase diameter, except the 25xs motor running in BMR.*
 - c) *Primers may be added and gas fittings installed in any carburetor or reed cage area. It is not permitted to use this as an accelerator pump or power jet.*
 - d) *Addition of thermal barrier coatings to piston crowns is approved. However, crown dimensions must remain as manufactured.*
- 18 *Alterations to carburetor and fuel systems are permitted as follows:*
- a) *For marathon use, an auxiliary fuel supply connection may be added to the carburetor.*
 - b) *The butterfly or idling needle must be altered as necessary for the automatic cut-off throttle to function properly.*
 - c) *Adapters or extra length high-speed needles are permitted.*
 - d) *Any inlet needle and seat may be used in any carburetor.*
 - e) *Material may be added to stiffen float levers in Carter model N carburetors.*
 - f) *Filters or fuel pressure regulators may be added to any fuel line.*
 - g) *All KA model Tillotson carburetors having a one inch venturi are legal for use on all class A,B, and D Modified engines provided they measure within KA7A model specifications and the use of adjustable high speed needles and seats from KA7A carburetors and conversion kit no. 2619A1 is permitted.*
 - h) *Fuel line cooling units are permitted.*
- 19 *Two-piece driveshafts are permitted and modifications to adapt approved lower unit gear housing to driveshaft housings are permitted.*
- 20 *Lower unit gear housings may be reduced to measurements as shown on the motor specifications sheets. The addition or removal of material on gear cases is permitted as long as “R” and “S” dimensions are maintained.*
- 21 *There are no water pump specifications on Modified gear units.*
- 22 *After-market pistons are permitted for use in all classes. However, they must meet all specifications for the class.*
- 23 *Any fuel pump is legal on any Modified motor.*

CLASS	Formal 400 MOD	Formula 400 MOD
ENGINE	OMC	MERCURY
<i>Min cc's to top of plug hole</i>	19.0	22.0
A		
A1		
C		
C1		
G	2.450 – 2.550	2.516 – 2.616
J	2.242 – 2.258	2.119 – 2.131
K	5.940 – 6.010	
M	6.625 Minimum	
N	1.700 Minimum	
<i>Min. Flywheel weight With Rope Plate *** OEM Weights</i>	3 Lb. 13 oz. – 2 magnet flywheel 2 Lb. 8 oz. – 1 magnet flywheel 4 Lb. Min. – OMC CD flywheel	OEM Weights 5 Lb. 4 oz.
Y		Brass, aluminum, or steel 1.3125 +/- 1/32
R/S Min	Mercury 2.0 / .875 Hot Rod 2.063 / .750	Mercury 2.0 / .875 Hot Rod 2.063 / .750
<i>Number & thickness of rings</i>	One .0625, .088 or 2 -.0625	Two or three .062 - .057
<i>Number of holes per cyl. in Reed Cage</i>	8 @ .531 - .563	4
<i>Carburetors</i>	One – OMC 25 Venturi 1.031 – 1.156 Throat 1.375 – 1.516	One Tillotson K series Venturi 1.0465 – 1.0785 Throat 1.234 – 1.266*****
<i>Number of intake ports per cylinder.</i>	4	3
<i>Number of exhaust ports per cylinder.</i>	4	3
<i>Reed cage surface</i>		Aluminum or Brass

NOTE

* OMC CD flywheel is of an eggshell design. It must be used as received from the manufacturer.

*KC16A Throat Measurement to be measured at point where butterfly contacts throat wall.

FORMULA 400 MODIFIED HYDRO CLASS

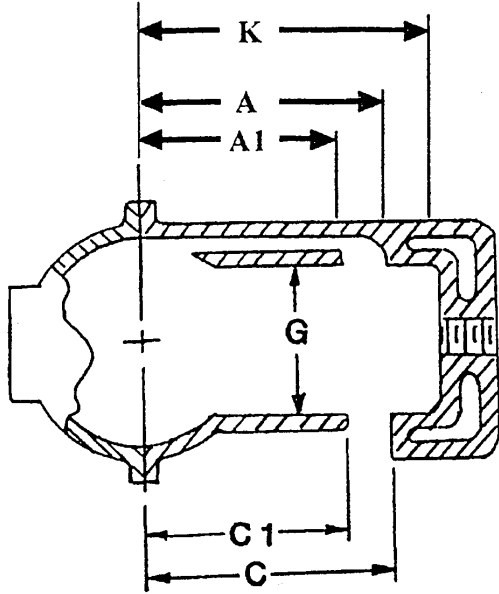

OMC Flywheel

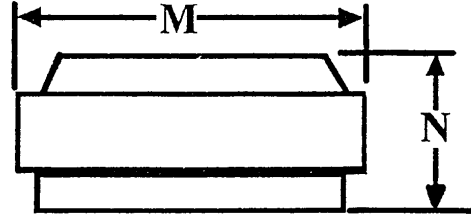

**Mercury
Reed Cage**

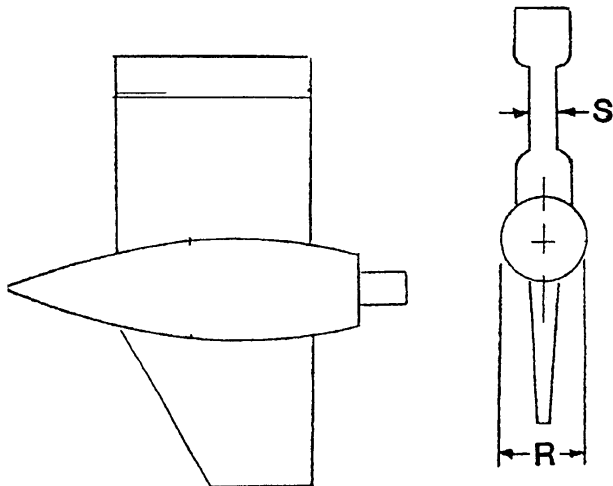
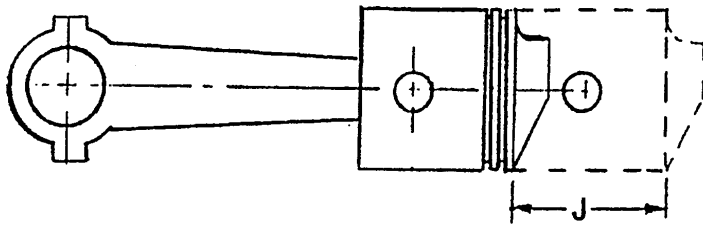
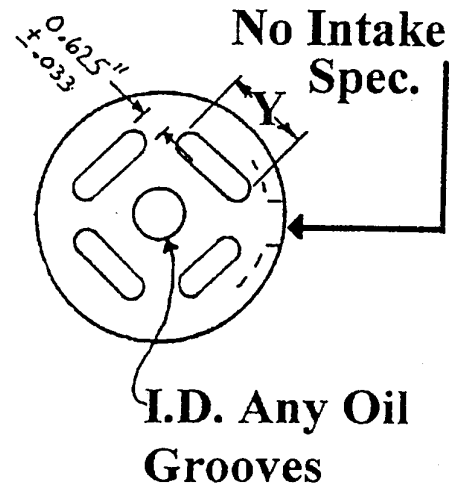

C MODIFIED OUTBOARD Class (Formerly 500cc)

CMH, CMR

Engine - YAMATO 102 & 300 SERIES

SPECIFIC TECHNICAL RULES FOR C MODIFIED YAMATO OUTBOARD

These specifications cover the Yamato 102 & 300 Series motors for use in the C Modified Class as manufactured by the Yamato Motor Co. of Japan. The engine shall be run in its stock form as received from the factory with only these exceptions. Any OEM part in question may be compared to a new part enabling inspection to discern legality.

- 1 Tuned exhaust will be permitted provided the powerhead is not modified to accept the exhaust. Expansion chambers or “can” type pipes are allowed. Sliding or moveable exhaust systems are allowed. It is the intent of this rule to allow an alternative exhaust system without significantly increasing the noise of the motor.*
- 2 Any propeller shaft is permitted. Diameters may be altered, and shear pin holes may be drilled or relocated. However, only one shear pin hole is permitted.*
- 3 The stock lower unit (102,202,300 series 14:15 ratio, underdrive) may be modified as follows: The shape and size of the gear housing may be altered by the addition or removal of material either externally or internally. Specifically, the R & S dimensions are retained but no other measurements apply. The placement of a water inlet pickup in/on the gear housing is permitted.*
- 4 Any make or material fabricated motor driveshaft housing and any make or type of clamp and swivel bracket is approved for use on the Yamato 102 and 300 series engines in the C Mod class. It is permitted to rotate the powerhead on the drive shaft housing*
- 5 Internal machined surfaces may be re-machined as long as minimum and maximum dimensions are maintained. Cast surfaces must remain as cast with no alterations, abrasive blasting or polishing. Note: It is not permissible to re-machine surfaces that do not have specific dimensions.*
- 6 Top fill and/or “float less” carburetors are permitted, provided that the carburetor body is not altered in any way (i.e. filing, drilling, sanding, or polishing),*
- 7 It is permissible to notch, drill or slot the top and bottom ends of the connecting rods at the crankshaft end for the purpose of improved lubrication.*
- 8 It is permissible to use repaired or “after-market” crank pins and bearings so long as the stroke and other specifications are maintained.*
- 9 It is permissible to mill the cylinder head. Motors must meet the cc specifications. No combustion chamber shape or configuration changes except for volume are permitted. It is allowable to machine the squish band on both Models 102 and 300 series cylinder heads (18 mm and 14 mm provided the new dimension H equals 2.597 – 2.627 and H1 equals 13 degrees min to 17 degree max angle are adhered to. A detectible edge must surround the squish band.*

- 10 (.020) oversize pistons provided by the manufacturer are permitted. Aftermarket Wiseco (.030) oversize pistons are also permitted. The (.030) Wiseco oversize piston P/N for the 100 series engine is 12952M06675. The (.030) Wiseco oversize piston P/N for the 300 series engine is 12951M6675. Wiseco oversize pistons are available from Cams Motor Sports (Mark Tate). The 14 mm spark plug head, or the 18 mm spark plug head is permitted. It is permissible to drill water drain holes in the ignition castings (coil, plates, and crankcase top end cap) and holes may be tapped and plugged.
- 11 All water plumbing modifications to move and/or vent water shall be off and through the exhaust stack plate. Water cooled filler blocks are permitted; however, no modifications may be made to the motor block to accommodate these. Additional water vents off the top of the stack plate are permitted and sealers may be used to seal the base of the filler block. It is permitted to bring extra water into the block via the stack plate and a water pickup attached to the boat. In addition, this pickup can be used to supply water to the factory water inlet hole at the base of the block. It is not permissible to block any water passages in the block to reroute water, etc. It is permissible to block any drain hole located in the bottom of the powerhead with a gasket, spacer plate, or down housing.
- 12 Only the following material may be added. Any type of spray shield, (carburetor intake tuning is prohibited) spark plug shield, throttle controls, kill switch hookup, chamber supports and controls, expansion chamber or tuned muffler, fuel pump, fuel filter, fuel pressure regulator, fuel lines and fittings, ignition advance and / or lockdown, (provided that the other parts are not altered to accommodate them, except that the factory spray shield mounting ears may be removed from the carburetor air horn).
- 13 Aftermarket cylinder sleeves for the Yamato 102 are legal provided they meet all applicable 102 specifications in this Tech Manual.
- 14 Aftermarket ignition coils for the Yamato 102 may be mounted in any location external of the OEM location. Addition of coil mounting brackets or coil mounting plates must not require internal modifications to the powerhead.
- 15 The aftermarket ignition system developed by Kyle Roskowski is legal on a C Yamato engine. Flywheel / rope plate weights are to be the same as the current C Yamato engine.

PERMISSIBLE MODIFICATIONS AND RESTRICTIONS for C YAMATO MODIFIED OUTBOARD

THE SPECIFIC DIMENSIONS AND TOLERANCES LISTED BELOW COMBINED WITH THE ABOVE MODIFIED OUTBOARD SPECIFIC CLASS RULES ARE THE ONLY TECHNICAL LIMITATIONS TO BE PLACED ON THE ENGINE BY INSPECTORS.

It is to be clearly understood that all engines, parts, etc. must comply with the dimensions and tolerances shown on the "Official Modified Outboard Specification Sheet". In cases of conflict, the specific class rules shall apply.

- 1 Any type or make of nut, bolt, screw, washer, spark plug, piston ring, propeller, ring pin, fuel line, fuel line fittings, starter plate, spacer plate assembly and ignition parts may be used. **Any bearing, seal, gasket may be used - 2025 Clarification**
- 2 The removal of integral gas tanks, spray shields, protective cowlings, spark plug protectors, compression release valves, fuel filters, starters and their mechanisms and carburetor chokes are permitted.

- 3 *Motors may be modernized with the use of parts manufactured for later model motors of the same class. However, if new parts differ from Modified Outboard specification sheets, approval of MORC is required. The interchange of parts from one motor to another in these classes is not permitted except where the manufacturer provides interchangeable parts.*
- 4 *Any make or material fabricated motor driveshaft housing and any make or type of clamp and swivel bracket is permitted.*
- 5 *The addition of metal to any drive shaft housings and lower unit gear housings is permitted for the specific purposes of strengthening these parts.*
- 6 *The addition of material for the specific purpose of installation of cavitation plates to drive shaft housings and spray shields and gas tanks to motors is permitted.*
- 7 *It is permitted to rotate the powerhead on the down housing.*
- 8 *It is not permissible to add material (including chrome plate) to cylinder walls.*
- 9 *Re-sleeving of cylinders is permitted.*
- 10 *Cylinder diameters may be bored, honed or ground to a maximum of 0.050" larger than the manufacturers mean dimension as listed under "G" in the motor specification sheets. Off center or slant boring of cylinders from normal stock center lines and perpendiculars is not permitted.*
- 11 *Broken or damaged parts may be repaired by welding or the use of plastic epoxy compounds, provided that all internal dimensions, contours and surfaces or parts are restored as closely as possible to original condition, within specifications. The inspector will pass repairs that meet the word and spirit of this rule and will disqualify engines having repairs which are obviously intended to provide an unfair advantage.*
- 12 *The addition of material for any purpose is prohibited except as noted:*
 - a) *Addition of material to the outside of piston skirts is approved, specifically meaning "coating" of skirts OD with a material to increase diameter.*
 - b) *Addition of thermal barrier coatings to piston crowns is approved. However, crown dimensions must remain as manufactured.*
 - c) *It is permissible to reposition the ring groove stop pin to allow the use of the Model 300 series piston in the Yamato 102 motor.*
- 13 *Alterations to carburetor and fuel systems are permitted as follows:*
 - a) *For marathon use, an auxiliary fuel supply connection may be added to the carburetor.*
 - b) *The butterfly or idling needle must be altered as necessary for the automatic cut-off throttle to function properly.*
 - c) *Any inlet needle and seat may be used in any carburetor.*
 - d) *Filters or fuel pressure regulators may be added to any fuel line.*
 - e) *Fuel line cooling units are permitted.*

C MODIFIED OUTBOARD CLASS
Yamato Engine

- 14 *Two-piece driveshafts are permitted and modifications to adapt approved lower unit gear housing to driveshaft housings are permitted.*
- 15 *Lower unit gear housings may be reduced to measurements as shown on the motor specifications sheets. The addition or removal of material on gear cases is permitted if "R" and "S" dimensions are maintained.*
- 16 *There are no water pump specifications on Modified gear units.*
- 17 *Aftermarket pistons are permitted for use in all classes. However, they must meet all specifications for the class.*
- 18 *Any make fuel pump is legal on any Modified motor.*
- 19 *It is permissible to tack weld repair any multiple piece crankshaft for the purpose of maintaining alignment.*

C MODIFIED OUTBOARD CLASS
Yamato Engine

ENGINE	102	300 SERIES
A	2.540 - 2.560	2.827 - 2.843
B	2.535 - 2.555	2.539 - 2.551
C	4.094 - 4.114	4.102 - 4.114
D (In Transfer Port Height)	1.885 - 1.915	1.890 - 1.913
D1 (Intake Boost Port Height)	1.845 - 1.900	1.772 - 1.827
D2 (Intake Transfer Port Width)	N/A	1.255 - 1.295
D3 (Intake Boost Port Width)	N/A	.978 - 1.018
E (Exhaust Port Height)	1.425 - 1.455	1.380 - 1.402
E1 (Exhaust Port Width)	N/A	1.791 - 1.831
F	.004 - .012	.004 - .012
G	.016 - .024	.016 - .024
H	2.597 – 2.627	2.597 – 2.627
H1	13 degrees min – 17 degrees max	13 degrees min – 17 degrees max
J	2.640 Max (2020 Ballot)	2.640 Max (2020 Ballot)
K	4.204 - 4.221	4.205 - 4.220
L	2.332 - 2.402	2.346 - 2.378
M	2.278 - 2.288	2.276 - 2.291
N	1.281 - 1.301	1.291 - 1.307
Reed Valve Plate	1 set (2 leaves x 2) 8 holes at .793 x 1.041	1 set (3 leaves x 3) 12 holes at .512 x 1.142
Reed Stop Height / Reed Thickness	No <u>spec</u> / .010 - .014	No spec / .010-.014
Carburetor = (1) - Mikuni BV36	Venturi 1.074 – 1.130 Throat 1.379 – 1.435	Venturi 1.074 – 1.130 Throat 1.379 – 1.435
Exhaust Holes	Two .835 x .945	One Oval
Piston Weight w/bearings, wristpins & fasteners	260 Grams Min.	260 Grams Min.
Rod Weight w/bearings, both ends, and washers	184 Grams Min.	191 Grams Min.
Min cc's top of plug hole	18mm 26.0 / 14mm 25.5	18 mm 26.0 / 14 mm 25.5
Gear Ratio	14:15	14:15
Flywheel Wt/Rope Pulley	1500 Grams Min / 315 Grams Min	1500 Grams <u>Min</u> / 315 Grams Min
R/S Minimum	2.205 Min / 1.195 Min	2.205 Min / 1.195 Min
Oversize Piston	.020	.020

YAMATO 300 SERIES EXHAUST

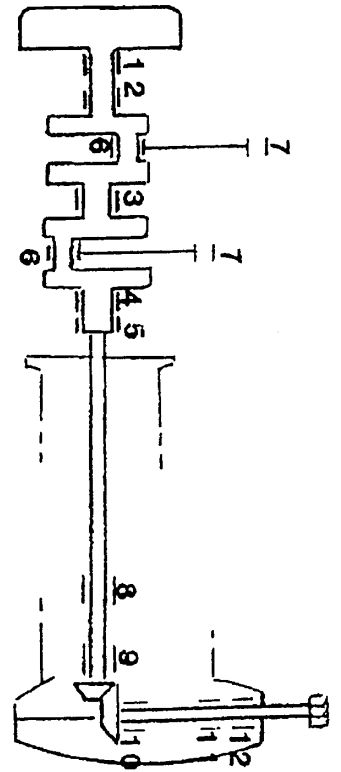
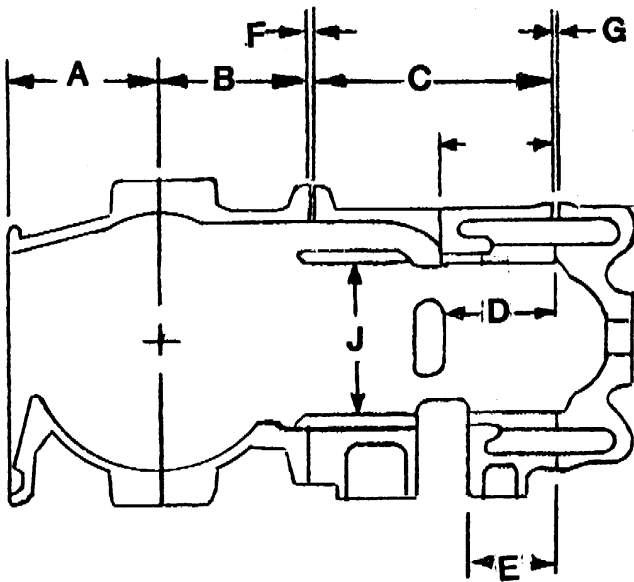
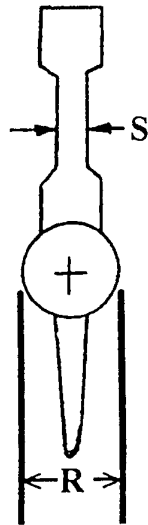
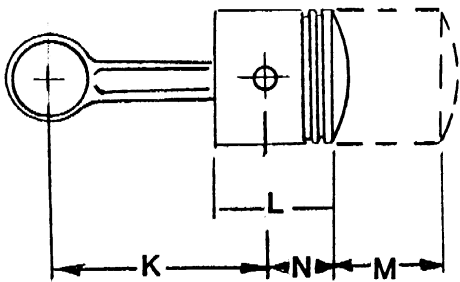
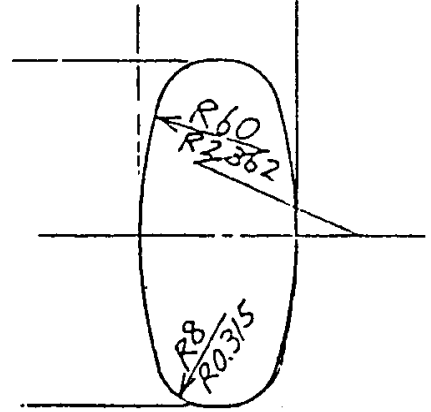
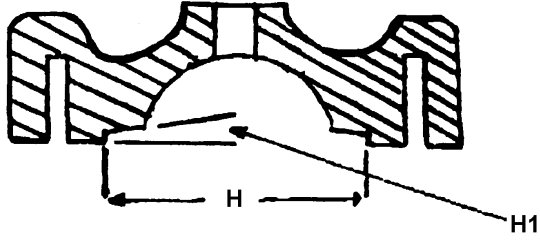

C MODIFIED OUTBOARD CLASS (Formerly 500cc)

CMH, CMR

Engines – Mercury 30H, Wizard 30

SPECIFIC TECHNICAL RULES for C Modified Mercury Outboard

1. *Pistons may be polished, knurled, or bead blasted. Diameters may be altered by machining. After market pistons are permitted for use, however, they must meet all specifications for the class*
2. *New type magneto adaptors for the 400 and 450 Mercury motors are permitted for use on four-cylinder engines. Machining and installation of a snap ring or comparable device on any magneto adapter is permitted.*
3. *On 500 Modified motor, one or two fuel pumps of any type may be used.*
4. *Any material may be used for reeds.*
5. *Wizard WA25 blocks are approved for use in the C Mod class. However, padded blocks are not permitted. It is permissible to use the 1995 /1996 Mercury 4 cylinder 40 hp intake port cover plate on C Modified Mercury motors.*
6. *Any gearcase in any ratio with a 1.750 minimum R dimension and a .875 minimum S dimension is permitted on C Modified Mercury motors.*
7. *You may use a D Modified motor crankshaft in a C Modified motor.*
8. *Any ignition system and/or flywheel is approved and modifications to adapt such system are permitted on C Modified motors.*
9. *It shall be permitted to remove the float assembly and/or install an overflow (floatless) system on any C Mod carburetor. The addition of material for a return fuel line is permitted*
10. *On C Mod Mercury motors carburetor studs may be relocated and old holes filled to facilitate mounting of permitted carburetors. It is permissible to use any single barrel carburetor used on a Mercury motor.*
11. *In C Mod material may be added to install a restrictor ring (flow enhancer) in the Venturi section of Tillotson model "KC" carburetors.*
12. *Modification by addition of material to extend the length of the high-speed nozzle on C Mod carburetors is permitted.*
13. *It is permitted to add a velocity stack (forced Venturi) to C Mod Mercury carburetors.*
14. *It is permissible to add material to fill the OEM water intake holes in the Mercury lower unit gear housings.*
15. *There are no restrictions to the C Mod Mercury reed cage.*

16. *It is legal to add an adapter to the front of the crank case, intake manifold, carburetor adaptor assembly with a maximum set-out distance on the carburetor base flanges at 2.0" from the original manifold location on the C Mod Mercury.*
17. *It is permissible to use any water jacket on all four-cylinder Mercury engines, providing the water jacket design does not interfere with the spark plugs or the measuring of cc's.*

PERMISSIBLE MODIFICATIONS AND RESTRICTIONS for C Modified Mercury

THE SPECIFIC DIMENSIONS AND TOLERANCES LISTED BELOW COMBINED WITH THE ABOVE MODIFIED OUTBOARD SPECIFIC CLASS RULES ARE THE ONLY TECHNICAL LIMITATIONS TO BE PLACED ON THE ENGINE BY INSPECTORS.

It is to be clearly understood that all engines, parts, etc. must comply with the dimensions and tolerances shown on the "Official Modified Outboard Specification Sheet". In cases of conflict, the specific class rules shall apply.

1. *Any type or make of nut, bolt, screw, washer, spark plug, piston ring, propeller, ring pin, fuel line, fuel line fittings, starter plate, spacer plate assembly and ignition parts may be used. **Any bearing, seal, gasket may be used - 2025 Clarification***
2. *The removal of integral gas tanks, spray shields, protective cowlings, spark plug protectors, compression release valves, fuel filters, starters and their mechanisms and carburetor chokes are permitted.*
3. *Motors may be modernized with the use of parts manufactured for later model motors of the same class. However, if new parts differ from Modified Outboard specification sheets, approval of MORC is required. The interchange of parts from one motor to another in these classes is not permitted except where the manufacturer provides interchangeable parts.*
4. *Open exhaust and special built or tuned exhaust systems are permitted. The addition of material to seal filler blocks and plug water outlets in blocks is permitted. Any new engines approved for use in the Modified category are not allowed to use open megaphone type exhaust systems.*
5. *Any make or material fabricated motor driveshaft housing and any make or type of clamp and swivel bracket is permitted.*
6. *The addition of metal to any drive shaft housings and lower unit gear housings is permitted for the specific purposes of strengthening these parts.*
7. *The addition of material for the specific purpose of installation of cavitation plates to drive shaft housings and spray shields and gas tanks to motors is permitted.*
8. *It is permitted to rotate the powerhead on the down housing.*

- 9 *Any make/material reed cage is permitted in mercury motors provided the following criteria is met:
 - a) Reed number, size, placement and design are the same as stock cage.
 - b) The crankcase does not have to be altered to accept the new cage.
 - c) No extra ports or passages are created in design.
 - d) Lies within specifications which will be shown on the official specification sheet
 - e) Size of reed port openings shall be measured 3/32 in. below the surface of the reed cage or near the surface if the opening is smaller there.*

- 10 *Any Mercury or Quincy production reed block may be used in any Mercury motor as long as it complies with specifications on the Official Modified Outboard Spec Sheet for the class, including the center main bearing surface. It is permitted to fill in oil slots and add material for the specific purpose of increasing the exterior diameter (The intent being to insure a tight fit/seal between the reed block exterior diameter and the crankcase). All surfaces of reed cages may be coated with neoprene or a suitable "plastic" to a maximum thickness of 0.040".*

- 11 *It is not permissible to add material (including chrome plate) to cylinder walls.*

- 12 *Re-sleeving of cylinders is permitted.*

- 13 *Cylinder diameters may be bored, honed or ground to a maximum of 0.050" larger than the manufacturers mean dimension as listed under "G" in the motor specification sheets. Off center or slant boring of cylinders from normal stock center lines and perpendiculars is not permitted.*

- 14 *Broken or damaged parts may be repaired by welding or the use of plastic epoxy compounds, provided that all internal dimensions, contours and surfaces or parts are restored as closely as possible to original condition, within specifications. The inspector will pass repairs that meet the word and spirit of this rule and will disqualify engines having repairs which are obviously intended to provide an unfair advantage.*

- 15 *Material may be added to or removed from flywheels for balance purposes. Service engine flywheels may be machined down to racing size and weights, provided the weight of such flywheel is not reduced to less than the minimum specified for that class engine. Flywheels must not be interchanged between classes unless specifically intended by the original engine manufacturer.*

- 16 *Removal of material from non-reciprocating parts (pistons and rod assemblies are classified as reciprocating) is permitted except as noted in these rules and specification sheets.*

- 17 *Removal of material from reciprocating parts, except for balancing and polishing is prohibited except where permitted in these rules and specification sheets.*

- 18 *The polishing of moving parts and passages is permitted except where prohibited by individual class rules and specification sheets.*

- 19 *Beveling of crankshafts is permitted except where removal of material is prohibited by individual class rules and specification sheets.*

C MODIFIED OUTBOARD CLASS
C Mercury Engine

- 20 No extra ports or passageways are allowed in the powerhead except where permitted in individual class rules and specification sheets.
- 21 Enlarging of intake and exhaust ports is permitted except where prohibited by individual class rules and specification sheets.
- 22 Removal of material by drilling holes, etc., into combustion chambers for the purpose of introducing water in that area is prohibited.
- 23 Indexing of pistons is permitted with the tolerances as specified in the “E” and “EE” measurement for that specific engine.
- 24 The addition of material for any purpose is prohibited except as noted:
- a) Elsewhere in these modified rules specifically.
 - b) Addition of material to the outside of piston skirts is approved, specifically meaning “coating” of skirts OD with a material to increase diameter.
 - c) Primers may be added, and gas fittings installed in any carburetor or reed cage area. It is not permitted to use this as an accelerator pump or power jet.
 - d). Addition of thermal barrier coatings to piston crowns is approved. However, crown dimensions must remain as manufactured.
 - e). It is permissible to reposition the ring groove stop pin
- 25 Alterations to carburetor and fuel systems are permitted as follows:
- a). The butterfly or idling needle must be altered as necessary in order for the automatic cut-off throttle to function properly.
 - b). Adapters or extra length high-speed needles are permitted.
 - c). Any inlet needle and seat may be used in any carburetor.
 - d). Material may be added to stiffen float levers in Carter model N carburetors.
 - e). Filters or fuel pressure regulators may be added to any fuel line.
 - f). All KA model Tillotson carburetors having a one-inch venture are legal provided they measure within KA7A model specifications and the use of adjustable high-speed needs and seats from KA7A carburetors and conversion kit no. 2619A1 is permitted.
 - g). Fuel line cooling units are permitted.
- 26 Two-piece driveshafts are permitted and modifications to adapt approved lower unit gear housing to driveshaft housings are permitted.
- 27 Lower unit gear housings may be reduced to measurements as shown on the motor specifications sheets. The addition or removal of material on gear cases is permitted as long as “R” and “S” dimensions are maintained.
- 28 There are no water pump specifications on Modified gear units.
- 29 After-market pistons are permitted for use in all classes. However, they must meet all specifications for the class.
- 30 Any fuel pump is legal on any Modified motor.

C MODIFIED OUTBOARD CLASS
C Mercury Engine

<i>CLASS</i>	<i>C MODIFIED</i>
<i>ENGINE</i>	<i>Mercury 30H</i>
<i>Min. cc's top of plug hole</i>	<i>16.0</i>
<i>G</i>	<i>2.107 - 2.162</i>
<i>J</i>	<i>2.115 - 2.129</i>
<i>R/S Min.</i>	<i>1.750/.875</i>
<i># and thickness of rings</i>	<i>1 to 3 rings / No spec</i>
<i># of holes per cylinder in reed cage</i>	
<i># intake ports per cylinder</i>	<i>3</i>
<i># exhaust ports per cylinder</i>	<i>3</i>
<i>Gear Ratio</i>	<i>See Specific rule # 6</i>
<i>Carburetors</i>	<i>Two Single Throat Mercury Carbs - See Specific Rule 11</i>

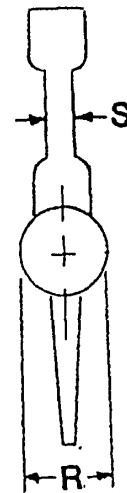
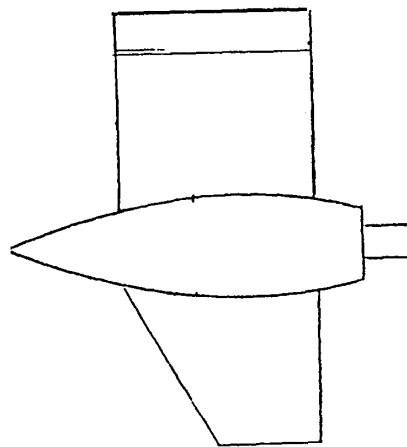
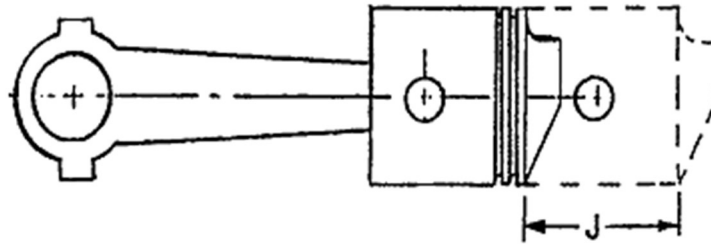
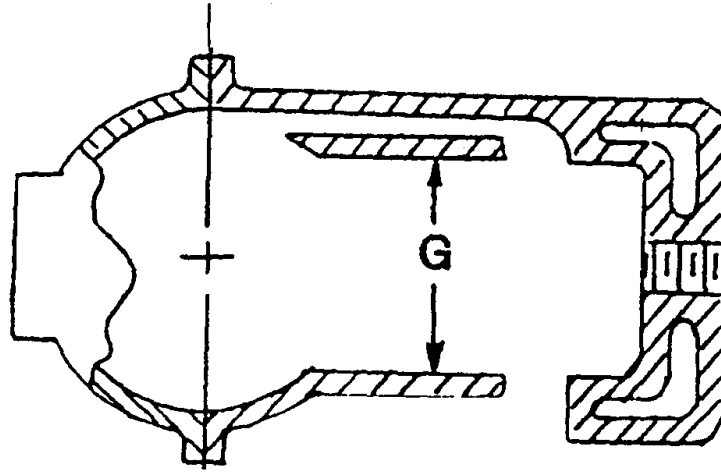

D MODIFIED OUTBOARD CLASS (Formerly 750cc)

DMH, DMR

Engine – 44 CI Mercury, 40 CI Mercury

SPECIFIC TECHNICAL RULES for D Modified Mercury Outboard

1. *Pistons may be polished, knurled, or bead blasted. Diameters may be altered by machining. After market pistons are permitted for use, however, they must meet all specifications for the class*
2. *New type magneto adaptors for the 400 and 450 Mercury motors are permitted for use on four-cylinder engines. Machining and installation of a snap ring or comparable device on any magneto adapter is permitted.*
3. *On D Modified motors one or two fuel pumps of any type may be used.*
4. *Any material may be used for reeds.*
5. *Any ignition system and / or flywheel is approved and modifications to adapt such system are permitted on D Modified motors.*
6. *There are no restrictions on removal of material from approved D Mod parts and there shall be no specifications except the following:*
 - a) *Minimum cc's at TDC shall be 21.5 for 44 cu in motors and 20.5 for 40 cu in engines.*
 - b) *Carburetors: two front mounted*
 - c) *Bore: 2.561 in. to a maximum of 2.611 for 44 cu. in. engines.*
 - d) *Bore: 2.441 in. to a maximum of 2.491 in. for a 40-cu. in. engine.*
 - e) *Stroke: 2.125 in. plus .004, minus .010 in.*
 - f) *There shall be no addition of material to motor parts except those specifically permitted within these rules.*
 - g) *There shall be no additional ports or passages added to the powerhead.*
7. *It shall be permitted to remove the float assembly and/or install an overflow (float less) system on any D Mod carburetor. The addition of material for a return fuel line is permitted.*
8. *On D Mod Mercury motors carburetor studs may be relocated and old holes filled to facilitate mounting of permitted carburetors.*
9. *In D Mod material may be added to install a restrictor ring (flow enhancer) in the Venturi section of Tillotson model "KC" carburetors.*
10. *Modification by addition of material to extend the length of the high-speed nozzle on D Mod carburetors is permitted.*
11. *It is permitted to add a velocity stack (forced Venturi) on D Mod carburetors.*
12. *Any gearcase that meets the "R" and "S" dimensions in either gear ratio 1:1 or 1 tooth reduction is permitted in the D Mod class.*

13. *It is permissible to add material to fill the OEM water intake holes in the Mercury lower unit gear housings*
14. *The only restriction to a D Mod motor reed cage is 4 openings per cylinder.*
15. *It is permissible to use any water jacket on all four-cylinder Mercury engines, providing the water jacket design does not interfere with the spark plugs or the measuring of cc's.*

PERMISSIBLE MODIFICATIONS AND RESTRICTIONS for Class D Mercury

THE SPECIFIC DIMENSIONS AND TOLERANCES LISTED BELOW COMBINED WITH THE ABOVE MODIFIED OUTBOARD SPECIFIC CLASS RULES ARE THE ONLY TECHNICAL LIMITATIONS TO BE PLACED ON THE ENGINE BY INSPECTORS.

It is to be clearly understood that all engines, parts, etc. must comply with the dimensions and tolerances shown on the "Official Modified Outboard Specification Sheet". In cases of conflict, the specific class rules shall apply.

1. *Any type or make of nut, bolt, screw, washer, spark plug, piston ring, propeller, ring pin, fuel line, fuel line fittings, starter plate, spacer plate assembly and ignition parts may be used. **Any bearing, seal, gasket may be used - 2025 Clarification***
2. *The removal of integral gas tanks, spray shields, protective cowlings, spark plug protectors, compression release valves, fuel filters, starters and their mechanisms and carburetor chokes is permitted.*
3. *Motors may be modernized with the use of parts manufactured for later model motors of the same class. However, if new parts differ from Modified Outboard specification sheets, approval of MORC is required. The interchange of parts from one motor to another in these classes is not permitted except where the manufacturer provides interchangeable parts.*
4. *Open exhaust and special built or tuned exhaust systems are permitted. The addition of material to seal filler blocks and plug water outlets in blocks is permitted. Any new engines approved for use in the Modified category are not allowed to use open megaphone type exhaust systems.*
5. *Any make or material fabricated motor driveshaft housing and any make or type of clamp and swivel bracket is permitted.*
6. *The addition of metal to any drive shaft housings and lower unit gear housings is permitted for the specific purposes of strengthening these parts.*
7. *The addition of material for the specific purpose of installation of cavitation plates to drive shaft housings and spray shields and gas tanks to motors is permitted.*
8. *It is permitted to rotate the powerhead on the down housing.*

MODIFIED OUTBOARD CLASS
D Mercury Engine

- 9 *Any Mercury or Quincy production reed block may be used in any Mercury motor as long as it complies with specifications on the Official Modified Outboard Spec Sheet for the class, including the center main bearing surface. It is permitted to fill in oil slots and add material for the specific purpose of increasing the exterior diameter (The intent being to insure a tight fit/seal between the reed block exterior diameter and the crankcase). Any and all surfaces of reed cages may be coated with neoprene or a suitable "plastic" to a maximum thickness of 0.040".*
- 10 *It is not permissible to add material (including chrome plate) to cylinder walls.*
- 11 *Re-sleeving of cylinders is permitted.*
- 12 *Cylinder diameters may be bored, honed or ground to a maximum of 0.050" larger than the manufacturers mean dimension as listed under "G" in the motor specification sheets. Off center or slant boring of cylinders from normal stock center lines and perpendiculars is not permitted.*
- 13 *Broken or damaged parts may be repaired by welding or the use of plastic epoxy compounds, provided that all internal dimensions, contours and surfaces or parts are restored as closely as possible to original condition, within specifications. The inspector will pass repairs that meet the word and spirit of this rule and will disqualify engines having repairs which are obviously intended to provide an unfair advantage.*
- 14 *Material may be added to or removed from flywheels for balancing purposes. Service engine flywheels may be machined down to racing size and weights, provided the weight of such flywheel is not reduced to less than the minimum specified for that class engine. Flywheels must not be interchanged between classes unless specifically intended by the original engine manufacturer.*
- 15 *Removal of material from non-reciprocating parts (pistons and rod assemblies are classified as reciprocating) is permitted except as noted in these rules and specification sheets.)*
- 16 *Removal of material from reciprocating parts, except for balancing and polishing is prohibited except where permitted in these rules and specification sheets.*
- 17 *The polishing of moving parts and passages is permitted except where prohibited by individual class rules and specification sheets.*
- 18 *Beveling of crankshafts is permitted except where removal of material is prohibited by individual class rules and specification sheets.*
- 19 *No extra ports or passageways are allowed in the powerhead except where permitted in individual class rules and specification sheets.*
- 20 *Enlarging of intake and exhaust ports is permitted except where prohibited by individual class rules and specification sheets.*
- 21 *Removal of material by drilling holes, etc., into combustion chambers for the purpose of introducing water in that area is prohibited.*

- 23 *Indexing of pistons is permitted.*
- 24 *The addition of material for any purpose is prohibited except as noted:*
- a) *Elsewhere in these modified rules specifically.*
 - b) *Addition of material to the outside of piston skirts is approved, specifically meaning “coating” of skirts OD with a material to increase diameter.*
 - c) *Primers may be added and gas fittings installed in any carburetor or reed cage area. It is not permitted to use this as an accelerator pump or power jet.*
 - d) *Addition of thermal barrier coatings to piston crowns is approved. However, crown dimensions must remain as manufactured.*
- 25 *Alterations to carburetor and fuel systems are permitted as follows:*
- a) *The butterfly or idling needle must be altered as necessary in order for the automatic cut-off throttle to function properly.*
 - b) *Adapters or extra length high-speed needles are permitted.*
 - c) *Any inlet needle and seat may be used in any carburetor.*
 - d) *Material may be added to stiffen float levers in Carter model N carburetors.*
 - e) *Filters or fuel pressure regulators may be added to any fuel line.*
 - h) *Fuel line cooling units are permitted.*
- 26 *Two-piece driveshafts are permitted and modifications to adapt approved lower unit gear housing to driveshaft housings are permitted.*
- 27 *Lower unit gear housings may be reduced to measurements as shown on the motor specifications sheets. The addition or removal of material on gear cases is permitted as long as “R” and “S” dimensions are maintained.*
- 28 *There are no water pump specifications on Modified gear units.*
- 29 *After-market pistons are permitted for use in all classes. However, they must meet all specifications for the class.*
- 30 *Any make fuel pump is legal on any Modified motor.*
- 31 *It is permissible to tack weld repair any multiple piece crankshaft for the purposes of maintaining alignment.*

MODIFIED OUTBOARD CLASS
D Mercury Engine

CLASS	<i>D Modified</i>	<i>D Modified</i>
ENGINE	<i>40 cu in Mercury</i>	<i>44 cu in Mercury</i>
<i>Min. cc's top of plug hole</i>	20.5	21.5
G	<i>2.436 - 2.491</i>	<i>2.561 - 2.611</i>
J	<i>2.115 - 2.129</i>	<i>2.115 - 2.129</i>
<i>R/S Min.</i>	<i>1.750/ .875</i>	<i>1.750/ .875</i>
<i># and thickness of rings</i>	<i>1 to 3 / .062</i>	<i>1 to 3 / .062-.057</i>
<i># of holes per cylinder in reed cage</i>	4	4
<i># intake ports per cylinder</i>	3	3
<i># exhaust ports per cylinder</i>	3	3
<i>Gear Ratio</i>	<i>See class rule # 12</i>	<i>See class rule # 12</i>
Carburetors	<i>2) KA, 2) KC, 2) Carter N, 2) Any Merc 44 cu in: w/ no venturi or throat dimensions or restrictions</i>	

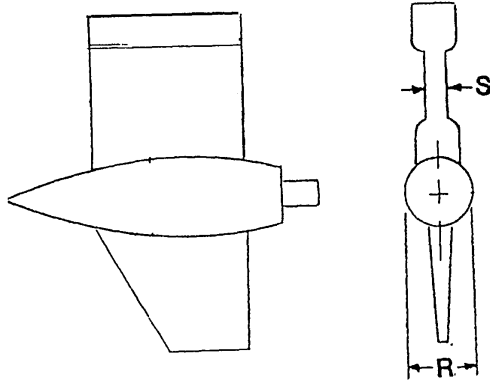
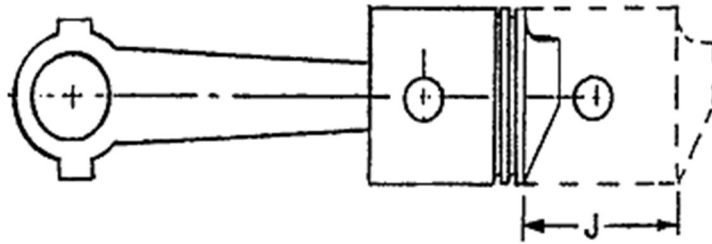
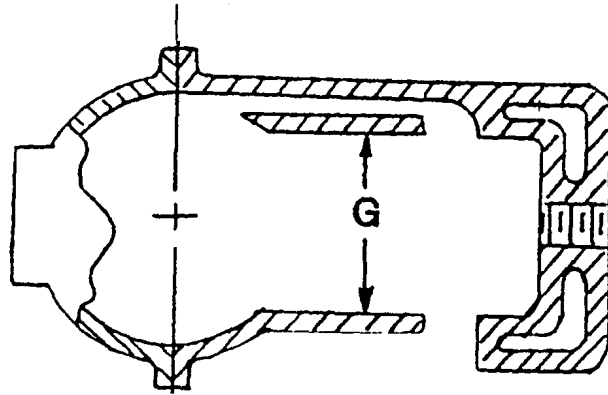

FORMULA E MODIFIED OUTBOARD CLASS (Formerly 850cc)

FEMH, FEMR, Modified TWO PERSON RUNABOUT

Engines – OMC 44.9 / 49.1 CI

Mercury- 44/60/62/66 CI

Mercury - 650XS – 49.9 CI

Yamaha - 50 – 42.6 CI

Tohatsu - MD50D2 – 42.6 CI

SPECIFIC TECHNICAL RULES for FE Modified Outboard POWERHEADS

1. *Only service outboard motor block and crankcases which meet all the following criteria are permitted.*
 - a) *Of which at least 1000 or more units were produced and offered for sale to the general public as service motors mounted on a service lower unit. Approved models before 1995 are grandfathered, and are permitted for competition in the 850 cc Modified class*
 - b) *Both foreign and domestic service motors are permitted and they shall both meet the MORC definition of a service motor.*
 - c) *Motors are limited to a minimum of 40 cu. in. and maximum of 49.9 cu. in. piston displacement, calculated as a function of the bore and stroke specified by the manufacturer for that specific service motor in standard bore configuration. Please note the following exceptions to this rule. Mercury Mark 75 (6 cyl. 60 cu. in.), Mercury Mark 78 (6 cyl. 66 C.I. with the same modifications as 44 cid (4 cyl. Mercury D modified class – 2024 rule, Mercury 650 XS (service powerhead) and Mercury 650 (4-cylinder 62 cu. in.) Service powerhead shall be permitted.*
 - d) *All motors manufactured before 1992 that meet the above criteria are automatically permitted to run, however, the MORC is given the authority to disapprove a specific model engine or specific part which violates the spirit of the service motor rule. Such disapproval shall be published as soon as possible and subjected to a driver referendum on the national ballot that follows.*
2. *Any new motors manufactured after 1992 must be presented to the MORC at the national meeting for approval along with ten (10) copies of motor specification sheets and factory manuals.*

MODIFICATION OF MOTORS

Other than the rules and specifications described in this section there are no technical limitations on modifications to the FE Modified class engines. You may add material, remove material, make parts and interchange parts

1. *NO special made/manufactured for racing engine blocks and/or crankcases will be permitted as replacement parts for service engines being modified. Production service blocks and/or crankcases that have been modified or not modified for racing are allowed. (2020 Commission)*
2. *You must start with and present for inspection a recognizable service motor block upon which you have built your 850 cc Mod engine. The block you use determines which make and model motor specifications apply to your engine.*

MODIFIED OUTBOARD CLASS
FE Modified Engines

3. Crankshaft stroke tolerance $+0.010$ inch. The engine block determines which specs are used. If the crankshaft you are using is out of another make/model motor, it must lie within the $+0.010$ and minus whatever tolerance for the crank that came with that block on manufacturers specs.
4. Maximum overbore is $.070$ from manufacturers mean specification for that motor block. Note: If a worn cylinder has an average ID $+0.071$ inches over mean spec it is not permitted. **Maximum overbore is $.090$ for the Tohatsu engine (only) to accommodate available oversize pistons. Note: If a worn cylinder has an average ID $+0.091$ inches over mean spec it is not permitted – Voted by class 2025**
5. No additional reed ports or carburetors are permitted on a motor from the number specified by the manufacturer. No other/additional means shall be used to introduce an air/fuel mixture into the engine crankcase area from outside the motor. On the OMC 49.7 cu in block, any OMC one barrel carburetor with a venturi of 1.250 (± 0.015) and a bore of 1.500 (± 0.015) may be used. On the 44.9 cu. in. OMC where any OMC outboard motor carburetor is permitted. This specific rule does not apply to the Mercury 4 cyl /44 cu. in. and 6 cyl. (60 cu. In) or 6 cyl. MK 78 (66 cu. in.) engines
6. On service engines that may use a design other than reed cage induction, the manufacturers specifications and tolerances shall be retained throughout the whole intake system from carburetor intake mouth to intake ports in the cylinder wall.
7. No superchargers or turbochargers are allowed. This refers to mechanical devices used to increase the amount of air/fuel mixture being fed into the engine. This does not refer to scoop or length tuning of the carburetor intake.
8. Mercury 650, 4 cyl 60/62 cu. in. motors may use any make, type or size carburetors, conventionally (front) mounted, 2 carburetors maximum, adapters may be added.
9. All APBA Modified safety rules apply and on carburetors or fuel injectors having throttle slide valves. They shall be adjusted to fully close.
10. Only single barrel carburetors are allowed, except 44.9 cu in OMC (45SS).

PERMISSIBLE MODIFICATIONS AND RESTRICTIONS for FE Modified Outboard

THE SPECIFIC DIMENSIONS AND TOLERANCES LISTED BELOW COMBINED WITH THE ABOVE MODIFIED OUTBOARD SPECIFIC CLASS RULES ARE THE ONLY TECHNICAL LIMITATIONS TO BE PLACED ON THE ENGINE BY INSPECTORS.

It is to be clearly understood that all engines, parts, etc. must comply with the dimensions and tolerances shown on the "Official Modified Outboard Specification Sheet". In cases of conflict, the specific class rules shall apply.

1. Any type or make of nut, bolt, screw, washer, spark plug, piston ring, propeller, ring pin, fuel line, fuel line fittings, starter plate, spacer plate assembly and ignition parts may be used. **Any bearing, seal, gasket may be used - 2025 Clarification**

MODIFIED OUTBOARD CLASS
FE Modified Engines

- 2 *The removal of integral gas tanks, spray shields, protective cowlings, spark plug protectors, compression release valves, fuel filters, starters and their mechanisms and carburetor chokes are permitted.*
- 3 *Motors may be modernized with the use of parts manufactured for later model motors of the same class. However, if new parts differ from Modified Outboard specification sheets, approval of MORC is required. The interchange of parts from one motor to another in these classes is not permitted except where the manufacturer provides interchangeable parts.*
- 4 *Open exhaust and special built or tuned exhaust systems are permitted. The addition of material to seal filler blocks and plug water outlets in blocks is permitted. Any new engines approved for use in the Modified category are not allowed to use open megaphone type exhaust systems.*
- 5 *Any make or material fabricated motor driveshaft housing and any make or type of clamp and swivel bracket is permitted.*
- 6 *The addition of metal to any drive shaft housings and lower unit gear housings is permitted for the specific purposes of strengthening these parts.*
- 7 *The addition of material for the specific purpose of installation of cavitation plates to drive shaft housings and spray shields and gas tanks to motors is permitted.*
- 8 *It is permitted to rotate the powerhead on the down housing.*
- 9 *Any make/material reed cage is permitted in mercury motors provided the following criteria is met:*
 - a) *Reed number, size, placement and design are the same as stock cage.*
 - b) *The crankcase does not have to be altered to accept the new cage.*
 - c) *No extra ports or passages are created in design.*
 - d) *Lies within specifications which will be shown on the official specification s*
 - e) *Size of reed port openings shall be measured 3/32 in. below the surface of the reed cage or near the surface if the opening is smaller there.*
- 10 *Any Mercury or Quincy production reed block may be used in any Mercury motor as long as it complies with specifications on the Official Modified Outboard Spec Sheet for the class, including the center main bearing surface. It is permitted to fill in oil slots and add material for the specific purpose of increasing the exterior diameter (The intent being to insure a tight fit/seal between the reed block exterior diameter and the crankcase). All surfaces of reed cages may be coated with neoprene or a suitable "plastic" to a maximum thickness of 0.040".*
- 11 *It is not permissible to add material (including chrome plate) to cylinder walls.*
- 12 *Re-sleeving of cylinders is permitted.*

MODIFIED OUTBOARD CLASS
FE Modified Engines

- 13 *Cylinder diameters may be bored, honed or ground to a maximum of 0.070" larger than the manufacturers mean dimension as listed under "G" in the motor specification sheets. Off center or slant boring of cylinders from normal stock center lines and perpendiculars is not permitted.*
- 14 *Broken or damaged parts may be repaired by welding or the use of plastic epoxy compounds, provided that all internal dimensions, contours and surfaces or parts are restored as closely as possible to original condition, within specifications. The inspector will pass repairs that meet the word and spirit of this rule and will disqualify engines from having repairs which are obviously intended to provide an unfair advantage.*
- 15 *Material may be added to or removed from flywheels for balance purposes. Service engine flywheels may be machined down to racing size and weights, provided the weight of such flywheel is not reduced to less than the minimum specified for that class engine. Flywheel must not be interchanged between classes unless specifically intended by the original engine manufacturer.*
- 16 *Removal of material from non-reciprocating parts (pistons and rod assemblies are classified as reciprocating) is permitted except as noted in these rules and specification sheets.*
- 17 *Removal of material from reciprocating parts, except for balancing and polishing is prohibited except where permitted in these rules and specification sheets.*
- 18 *The polishing of moving parts and passages is permitted except where prohibited by individual class rules and specification sheets.*
- 19 *Beveling of crankshafts is permitted except where removal of material is prohibited by individual class rules and specification sheets.*
- 20 *No extra ports or passageways are allowed in the powerhead except where permitted in individual class rules and specification sheets.*
- 21 *Enlarging of intake and exhaust ports is permitted except where prohibited by individual class rules and specification sheets.*
- 22 *Removal of material by drilling holes, etc., into combustion chambers for the purpose of introducing water in that area is prohibited.*
- 23 *Indexing of pistons is permitted with the tolerances as specified in the "E" and "EE" measurement for that specific engine.*
- 24 *The addition of material for any purpose is prohibited except as noted:*
 - a) *Elsewhere in these modified rules specifically.*
 - b) *Addition of material to the outside of piston skirts is approved, specifically meaning "coating" of skirts OD with a material to increase diameter.*
 - c) *Primers may be added, and gas fittings installed in any carburetor or reed cage area. It is not permitted to use this as an accelerator pump or power jet.*
 - d) *Addition of thermal barrier coatings to piston crowns is approved. However, crown dimensions must remain as was manufactured.*

- 25 *Alterations to carburetor and fuel systems are permitted as follows:*
- a). *The butterfly or idling needle must be altered as necessary in order for the automatic cut-off throttle to function properly.*
 - b). *Adapters or extra length high-speed needles are permitted.*
 - c). *Any inlet needle and seat may be used in any carburetor.*
 - d). *Material may be added to stiffen float levers in Carter model N carburetors.*
 - e). *Filters or fuel pressure regulators may be added to any fuel line.*
 - f). *Fuel line cooling units are permitted.*
- 26 *Two-piece driveshafts are permitted and modifications to adapt approved lower unit gear housing to driveshaft housings are permitted.*
- 27 *Lower unit gear housings may be reduced to measurements as shown on the motor specifications sheets. The addition or removal of material on gear cases is permitted as long as "R" and "S" dimensions are maintained.*
- 28 *There are no water pump specifications on Modified gear units.*
- 29 *After-market pistons are permitted for use in all classes. However, they must meet all specifications for the class.*
- 30 *Any make fuel pump is legal on any Modified motor.*
- 31 *It is permissible to tack weld repair any multiple piece crankshaft for the purposes of maintaining alignment.*

ENGINES

OMC 44.9 / 49.1 CI

1. *On the OMC 49.7 cu in block, any OMC one barrel carburetor with a venturi of (+/- 0.015) and a bore of 1.500 (+/- 0.015) may be used. On the 44.9 cu. in. OMC where any OMC outboard motor carburetor is permitted.*

MERCURY 6 CYLINDER 60 CU. / 66 cu.in. MOTORS - see spec sheet

1. *Fueling may only be accomplished through and via a maximum of 3 conventionally mounted, single barrel carburetors of any make or size.*
2. *It is not permissible to have removable cylinder heads on this motor.*

MERCURY 4 CYLINDER 60/62 CU. IN. MOTORS – see spec sheet

1. *Fueling may only be accomplished through and via a maximum of 2 conventionally mounted, single barrel carburetors of any make or size.*

TOHATSU M50D2 MOTOR – see spec chart

1. *Any material may be used for reeds.*
2. *Any make or material reed cage.*
3. *There shall be no addition of material to motor parts except those specifically permitted within these rules.*
4. *Gearcase minimums R-1.750/ S Dimension removed (2020 Ballot)*
5. *Any Carburetor with a 40mm venture is permissible.*

ENGINES (Continued)

Yamaha - 50 – 42.6 CI

SUZUKI DF – DF 50 , 4 CYCLE 50 HP MOTORS

1. Engine deleted by ballot - 2020

LOWER UNITS

1. *There shall be no restrictions except:*
 - a) *No tractor units*
 - b) *The gear housing shall have a minimum “R” dimension of 1.750 inches.*
 - c) *Engines with power tilt, lift and/or trim are not permitted unless those devices are securely disconnected and inoperable while underway.*

FUEL

This class is covered by the Modified Outboard fuel rule and no nitrous oxide or other power boost injection is allowed.

BOATS

Reference Modified Rule concerning hydroplanes exceptions are as follows:

- 1 *Tunnel boats. - Maximum lateral steps shall not exceed 5 inches at the transom area. The transom area is defined as the center line extended from the transom board to which the engine is attached, and then proceeding down this line until intersecting the plane (or extended line of this plane) of the tunnel(s). Go port and starboard to the inside edges of the outside tunnels and measure the depth at that point. If the tunnel bottoms do not extend back that far then measure them where they end forward of the transom area.*
- 2 *The FE Modified class can use a transom rudder system for steering purposes which is not retractable and cannot be elevated while underway.*

FE / TWO PERSON RUNABOUT MOTOR SPECIFICATIONS

INSPECTABLE ITEM	OMC 40-60 HP	OMC 60-70 HP	MERC 44	MERC 6 Cyl MK 75 / MK7	MERC 650	MERC 650 XS	YAM. 50	SUZUKI DF- 50 (Deleted 2020)	Tohatsu M50D2
Displacement Cu. In.	44.9	49.7	44	60/ 66	62.4	49.9	42.6		42.6
# Cylinders	2	3	4	6/ 6	4	3	3		3
Standard Bore	3.187	3.000	2.567	2.441/ 2.565	2.938	2.875	2.638		2.676 – 2.698
Stroke	2.810-2.830	2.334-2.354	2.115-2.135	2.115-2.135	2.292-2.312	2.552-2.572	2.588-2.608		2.518 – 2.522
# Carburetors	2	3		3 / 3	2	3	3		3 Front mounted single barrel carburetors with Venturi 40 mm Max.
# Reed Port Openings Per Cylinder	8	6		60cu in – N/A 66 - 4 openings per cylinder	8	14	4		

NOTE: The above chart is an aid for inspection purposes. It contains the more popular model engines currently being raced in Formula E and Mod 2-person runabout class. It is by no means a complete list of engines permitted to be run in the class.